

R.O.W. # 18601

NORTHWESTERN BELL TELEPHONE COMPANY
- EASEMENT -
(BURIED, AERIAL AND UNDERGROUND FACILITIES)

The undersigned owner(s) of an interest in the real estate described below (Hereinafter called "Owner") hereby grant(s) and convey(s) to NORTHWESTERN BELL TELEPHONE COMPANY, an Iowa Corporation, its associated and allied companies, its and their respective successors, assigns, lessees and agents (Hereinafter called "Company"), in consideration of the sum of THREE HUNDRED FORTY SIX & 99/100 Dollars (\$ 346.99) received from the Company and of the agreements stated below, a right-of-way and easement to install, construct, operate, maintain, replace, and remove such communications systems as the Company may from time to time require. Said communications systems may consist of poles, aerial cable, buried cable or conduit, manholes, surface terminals, surface markers (at fence lines, if any) and associated equipment which will be installed, maintained, reinforced, or removed as the Company may deem necessary for the purpose of exercising the rights herein granted, including rights of ingress and egress, upon, under, across, over and through the following described real estate located in the County of SARPY, State of NEBRASKA.
More specifically described as:

See Exhibit "A" Attached.

FILED
INSTRUMENT NUMBER
89-13787

OCT-6 AM 10:55
REGISTER OF DEEDS

INDEXED
PAID
GRANTED
RECORDED
FILED
105

1st copy

N of W

The Company agrees to install all facilities designed for underground installation at sufficient depth so as to not interfere with Owner's present normal usage of the land, and to pay for all damage to Owner's property arising from the Company's exercise of the rights herein granted.

Signed this fifth day of October, 19 89.

WITNESS _____ OWNER Dennis Karloff
Karloff Farm Co.

ACKNOWLEDGEMENT

STATE OF NEBRASKA
COUNTY OF Douglas) SS

On this the 5th day of October, 19 89,
before me, _____, the undersigned officer,
personally appeared DENNIS KARLOFF

known to me or satisfactorily proven to be the person(s) whose name(s) _____
subscribed to the within instrument and
acknowledged that _____ executed the same for the purpose
therein contained.

IN WITNESS WHEREOF, I hereunto set my hand and official seal.

James Merrill
Notary Public

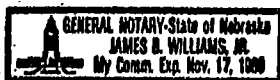

89-13787A

EXHIBIT "A"

R.O.W. # 18601

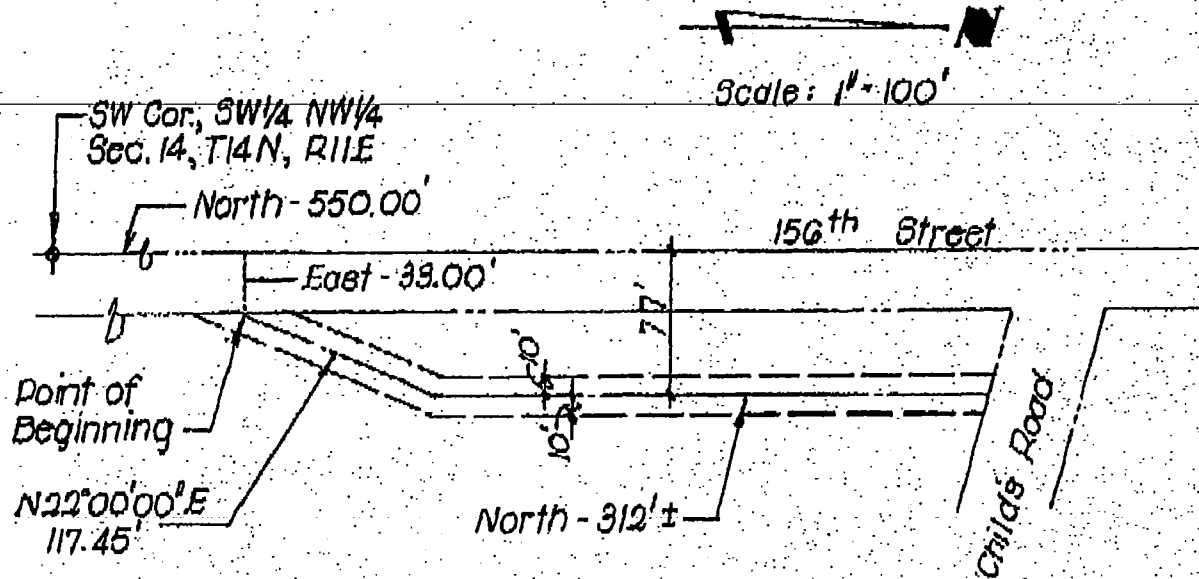

Legal Description:

A 20.00 foot wide strip of land lying within the SW 1/4 of the NW 1/4 of Section 14, T14N, R11E of the 6th P.M., Sarpy County, Nebraska, the centerline of said 20.00 foot wide strip of land being more particularly described as follows: Commencing at the SW corner of said SW 1/4; thence North (assumed bearing) 550.00 feet on the West line of said SW 1/4; thence East 33.00 feet to the point of beginning said point being on the East right-of-way line of 156th Street; thence N22°00'00"E 117.45 feet; thence North 312 feet more or less on a line 77.00 feet East of and parallel to the West line of said SW 1/4 to the South right-of-way line of Childs Road and the point of termination, with the outer boundaries of said 20.00 foot wide strip of land being extended to meet the South right-of-way of Childs Road and the East right-of-way of 156th Street.