

DEED 2016052188
 JUL 01 2016 14:53 P 10

DEED 10/18 20-16850
 REC'D 4.00 10.20-10920
 Received - DIANE L. BATTIATO
 Register of Deeds, Douglas County, NE
 7/8/2016 14:53:17
 2016052188

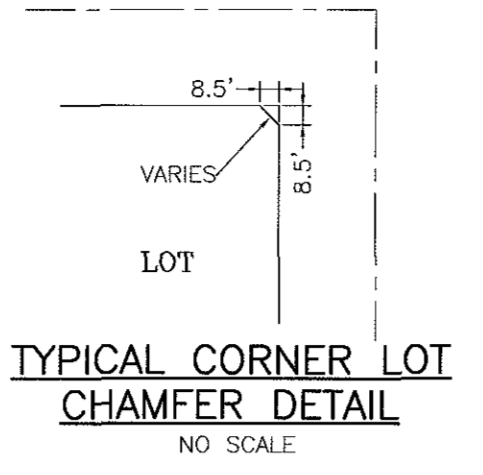

- NOTES**
1. ALL DISTANCES ARE SHOWN IN DECIMAL FEET.
 2. ALL ANGLES ARE 90° UNLESS OTHERWISE NOTED.
 3. DISTANCES AND ANGLES SHOWN IN PARENTHESES REFER TO EASEMENTS.
 4. ALL EXISTING EASEMENTS ARE NOT BEING REDEDICATED AND ARE SHOWN FOR REFERENCE ONLY.
 5. POWER AND COMMUNICATION EASEMENTS WILL BE GRANTED AS NEEDED VIA SEPARATE RECORDED DOCUMENTS.

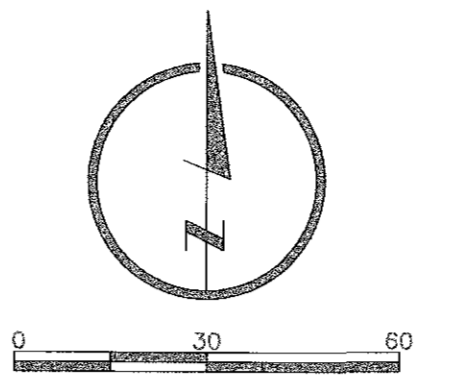

- LEGEND**
- BOUNDARY LINE
 - EASEMENT LINE
 - LOT LINE
 - STREET DEDICATION
 - CORNERS FOUND
 - CORNERS SET (5/8" REBAR WITH 1 1/4" YELLOW PLASTIC CAP STAMPED LS-692)
 - SOLID BAR
 - PINCH TOP PIPE
 - OPEN TOP PIPE

MAYBERRY PLACE

LOCATED IN:
 SW 1/4 SE 1/4 SEC. 19-15-13

LOT 1, BEING A REPLATING OF PART OF LOT 33, BLOCK 2, HIMEBAUGHS ADDITION, TOGETHER WITH LOTS 1 THROUGH 8 AND PART OF LOTS 21 THROUGH 28, ELDORA, AND TOGETHER WITH VACATED MARCY STREET, AND ALSO TOGETHER WITH PART OF THE VACATED ALLEY NORTH OF LOTS 1 THROUGH 8, ALL IN DOUGLAS COUNTY, NEBRASKA.

LAND SURVEYOR'S CERTIFICATE

I HEREBY CERTIFY THAT I HAVE MADE A BOUNDARY SURVEY OF THE SUBDIVISION HEREIN AND THAT PERMANENT MONUMENTS HAVE BEEN PLACED AT ALL CORNERS, ANGLE POINTS AND ENDS OF CURVES ON THE BOUNDARY ON THE PLAT AND THAT PERMANENT MONUMENTS WILL BE PLACED AT ALL CORNERS, ANGLE POINTS AND ENDS OF CURVES ON ALL LOTS AND STREETS WITHIN THE SUBDIVISION TO BE KNOWN AS MAYBERRY PLACE, LOT 1, BEING A REPLATING OF THE SOUTH 91.00 FEET OF THE EAST 250.00 FEET OF LOT 33, IN BLOCK 2, IN HIMEBAUGHS ADDITION, AN ADDITION TO THE CITY OF OMAHA, AS SURVEYED, PLATTED AND RECORDED, IN DOUGLAS COUNTY, NEBRASKA, AND TOGETHER WITH THE NORTH 25.00 FEET OF LOTS 1, 2, 3, 4 AND 5, IN ELDORA, AN ADDITION TO THE CITY OF OMAHA, AS SURVEYED, PLATTED AND RECORDED, IN DOUGLAS COUNTY, NEBRASKA; AND TOGETHER WITH ALL OF THE VACATED ALLEY ADJACENT TO SAID PORTION OF LOT 33 ON THE SOUTH AND ADJACENT TO SAID PORTIONS OF LOTS 1, 2, 3, 4 AND 5 ON THE NORTH, AND ALSO TOGETHER WITH THE SOUTH 111 FEET OF LOTS 1, 2, 3, 4 AND 5, AND ALL OF LOTS 6, 7, 8, 21, 22, 23 AND 24, IN ELDORA, AN ADDITION TO THE CITY OF OMAHA, AS SURVEYED, PLATTED AND RECORDED, IN DOUGLAS COUNTY, NEBRASKA, TOGETHER WITH ALL OF VACATED MARCY STREET ADJACENT TO SAID LOTS 1, 2, 3, 4, 5, 6, 7 AND 8 ON THE SOUTH, AND TOGETHER WITH THE SOUTH HALF (S1/2) OF THE VACATED ALLEY ADJACENT TO SAID LOTS 6, 7 AND 8 ON THE NORTH, EXCEPT THE SOUTH 20 FEET OF SAID LOTS 21, 22, 23 AND 24 APPROPRIATED BY THE CITY OF OMAHA FOR OPENING MAYBERRY STREET AND 51ST AVENUE. AND ALSO TOGETHER WITH LOT 25 AND THE WEST 32 FEET OF LOT 26, IN ELDORA, AN ADDITION TO THE CITY OF OMAHA, AS SURVEYED, PLATTED AND RECORDED, IN DOUGLAS COUNTY, NEBRASKA, EXCEPT THE SOUTH 20 FEET OF SAID LOTS APPROPRIATED BY THE CITY OF OMAHA FOR OPENING MAYBERRY STREET. AND ALSO TOGETHER WITH THE EAST 18 FEET OF LOT 26 AND ALL OF LOTS 27 AND 28, IN ELDORA, AN ADDITION TO THE CITY OF OMAHA, AS SURVEYED, PLATTED AND RECORDED, IN DOUGLAS COUNTY, NEBRASKA, EXCEPT THE SOUTH 20 FEET OF SAID LOTS APPROPRIATED BY THE CITY OF OMAHA FOR OPENING MAYBERRY STREET. THE ENTIRE PARCEL IS DESCRIBED AS FOLLOWS:

BEGINNING AT A 5/8" SOLID BAR AT THE INTERSECTION OF THE NORTH RIGHT OF WAY LINE OF MAYBERRY STREET AND THE WEST RIGHT OF WAY LINE OF SOUTH 51ST STREET; THENCE SOUTH 87°29'23" WEST FOR 400.01 FEET ON THE NORTH RIGHT OF WAY LINE OF MAYBERRY STREET TO A 10 A 5/8" REBAR WITH 1 1/4" YELLOW PLASTIC CAP STAMPED LS 692 ON THE EAST LINE OF LOT 20, ELDORA; THENCE NORTH 02°31'24" WEST FOR 306.71 FEET ON THE EAST LINE OF LOT 20 AND LOT 9, ELDORA PROJECTED TO A 3/4" PINCHED TOP PIPE AT THE CENTERLINE OF THE VACATED ALLEY NORTH OF SAID LOT 9; THENCE NORTH 87°29'32" EAST FOR 149.63 FEET ON SAID CENTERLINE TO A 3/4" PINCHED TOP PIPE; THENCE NORTH 02°23'20" WEST FOR 95.67 FEET TO A 3/4" OPEN TOP PIPE; THENCE NORTH 87°34'47" EAST FOR 249.61 FEET TO A 5/8" REBAR ON THE WEST RIGHT OF WAY LINE OF SOUTH 51ST STREET; THENCE SOUTH 02°36'07" EAST FOR 401.98 FEET TO THE POINT OF BEGINNING. CONTAINS 146,466 SQUARE FEET OR 3.362 ACRES AS FIELD MEASURED.

Matthew R. Tinkham, L.S. 692
 3-25-2016

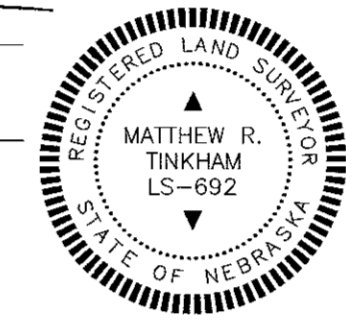

DEDICATION

KNOW ALL PERSONS BY THESE PRESENTS: THAT WE, MAYBERRY 51, LLC, OWNERS AND U.S. BANK, MORTGAGEES, OF THE LAND DESCRIBED IN THE LAND SURVEYOR'S CERTIFICATE AND EMBRACED WITHIN THIS PLAT, HAVE CAUSED SAID LAND TO BE SUBDIVIDED INTO LOTS AND STREETS TO BE NUMBERED AND NAMED AS SHOWN HEREON, SAID SUBDIVISION TO BE HEREAFTER KNOWN AS MAYBERRY PLACE, LOT 1; DO HEREBY RATIFY AND APPROVE OF THE DISPOSITION OF OUR PROPERTY AS SHOWN ON THIS PLAT, AND WE DO HEREBY DEDICATE TO THE PUBLIC THE STREETS AS SHOWN HEREON.

MAYBERRY 51, LLC, OWNER
 Christian Christensen, PRESIDENT

U.S. BANK, MORTGAGEE

Stephen G Bodner, PRESIDENT
 Sr. V.P.

ACKNOWLEDGEMENT OF NOTARIES

STATE OF NEBRASKA)
 COUNTY OF DOUGLAS)
 THE FOREGOING INSTRUMENT WAS ACKNOWLEDGED BEFORE ME THIS 28th DAY OF March 2016 BY Christian Christensen, PRESIDENT OF MAYBERRY 51, LLC A NEBRASKA LIMITED LIABILITY COMPANY, ON BEHALF OF SAID COMPANY. SIGNATURE OF NOTARY PUBLIC: KASSANDRA INNESS, My Comm. Exp. June 25, 2019. STATE OF NEBRASKA)
 COUNTY OF DOUGLAS)
 THE FOREGOING INSTRUMENT WAS ACKNOWLEDGED BEFORE ME THIS 28th DAY OF March 2016 BY Stephen G Bodner, SENIOR VP OF U.S. BANK ON BEHALF OF SAID BANK. SIGNATURE OF NOTARY PUBLIC: JEFFREY L BAKWELL, My Commission Expires November 28, 2017.

REVIEW BY DOUGLAS COUNTY ENGINEER

THIS PLAT OF MAYBERRY PLACE, LOT 1 WAS REVIEWED BY THE DOUGLAS COUNTY ENGINEER'S OFFICE. DATE: 3/25/2016. Douglas County Engineer: [Signature]



APPROVAL OF CITY ENGINEER OF OMAHA

I HEREBY APPROVE THIS PLAT OF MAYBERRY PLACE, LOT 1, AS TO THE DESIGN STANDARDS. DATE: 3/29/16. City Engineer: [Signature]

COUNTY TREASURER'S CERTIFICATE

THIS IS TO CERTIFY THAT I FIND NO REGULAR NOR SPECIAL TAXES DUE OR DELINQUENT AGAINST THE PROPERTY DESCRIBED IN THE LAND SURVEYOR'S CERTIFICATE AND EMBRACED IN THIS PLAT, AS SHOWN BY THE RECORDS OF THIS OFFICE, THIS 1 DAY OF July 2016. Douglas County Treasurer: [Signature]

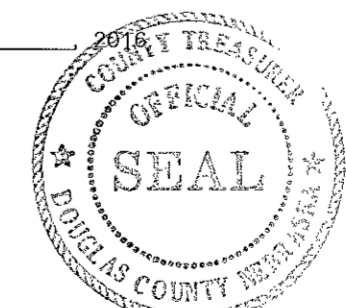

APPROVAL OF OMAHA CITY PLANNING BOARD

THIS PLAT OF MAYBERRY PLACE, LOT 1 WAS APPROVED BY THE OMAHA CITY PLANNING BOARD THIS 3 DAY OF February 2016. Omaha City Planning Board: [Signature]

APPROVAL OF OMAHA CITY COUNCIL

THIS PLAT OF MAYBERRY PLACE, LOT 1 WAS APPROVED AND ACCEPTED BY THE CITY COUNCIL OF OMAHA, NEBRASKA, THIS 17 DAY OF May 2016. Mayor: [Signature], City Clerk: [Signature], President: [Signature]

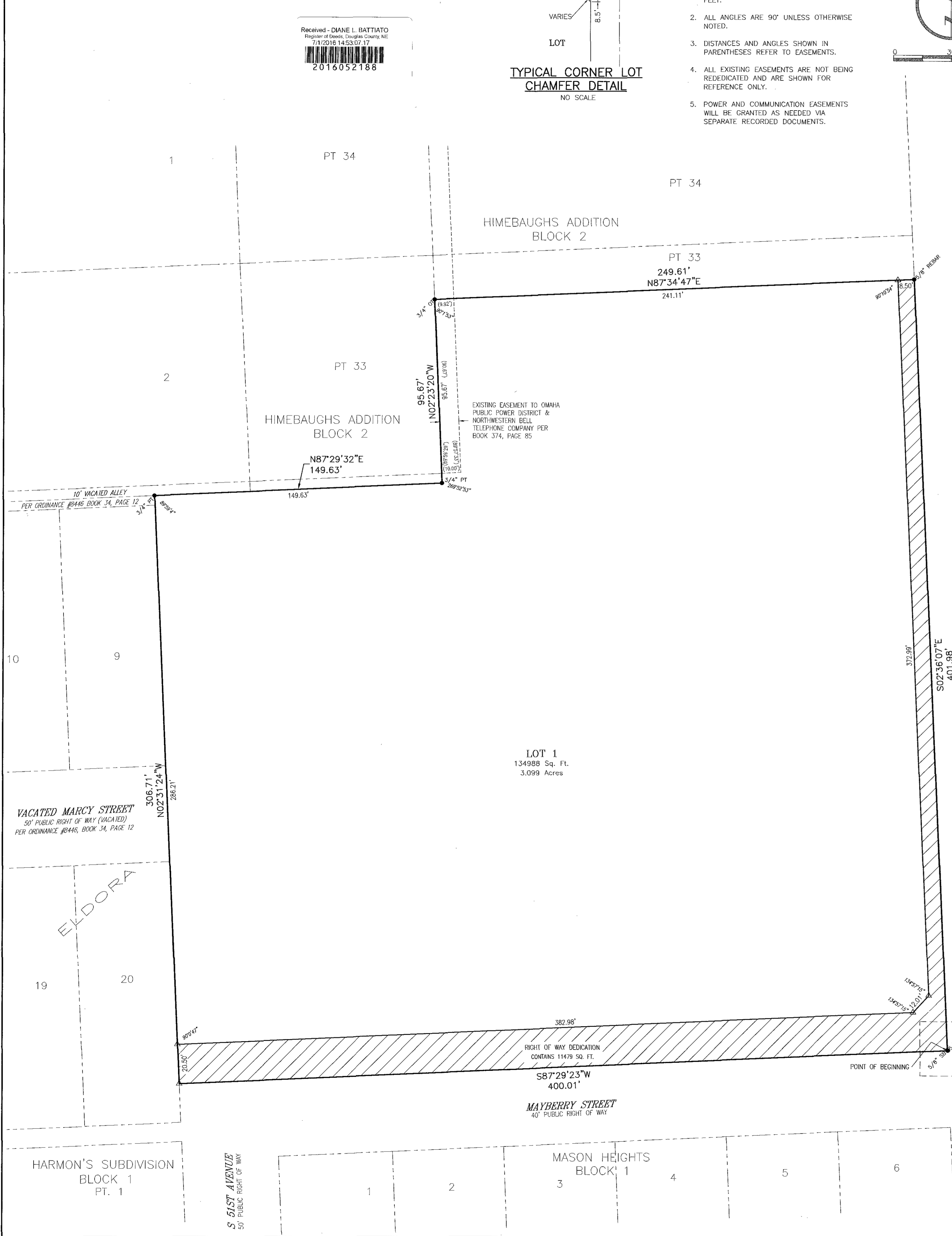

12 DODGES SUBDIVISION HIMEBAUGHS ADDITION

HIMEBAUGH & PATTERSONS BLOCK 2

drawn by EAM
 designed by
 reviewed by MET
 reference: 15048001, 0115048100, 0115048102
 revision:
 14710 West Dodge Road, Suite 100, Omaha, Nebraska 68154-2027
 402.496.2498
 402.496.2730
 www.LRA-inc.com
 LAMP RYNEARSON & ASSOCIATES
 MAYBERRY PLACE (LOT 1) OMAHA, DOUGLAS COUNTY, NEBRASKA
 MINOR PLAT
 Job number-tasks: 0115048.01-004
 book page: 15048 1-9
 date: 12-11-2015
 sheet 1 of 1

U:\Projects\0115048\0115048.dwg (0115048) 3/25/2016 2:18:52 PM, USER: A. WOLFE, LAMP RYNEARSON & ASSOCIATES