



2094 446 DEED



05011 58 445-470

RICHARD N. TAKECHI
REGISTER OF DEEDS
DOUGLAS COUNTY, NE

98 JUL -8 PM 3:28

RECEIVED

THIS PAGE INCLUDED FOR INDEXING
PAGE DOWN FOR BALANCE OF INSTRUMENT

NEBRASKA DOCUMENTARY
STAMP TAX
Date 7-8-98
524.87

9011 y MI-00502 (new)
01-60000 old

FEE 52 FB _____
BKP 55/15-11 C/C _____ COMP MB 18
DEL PN SCAN dc FY _____

ALTECH BUSINESS PARK

A CLUSTER SUBDIVISION
LOTS 1 THRU 50, INCLUSIVE & OUTLOTS A, B, C AND D

BEING A PLATTING OF PART OF THE EAST 1/2 OF SECTION 35, T15N, R11E OF THE 6TH P.M., DOUGLAS COUNTY, NEBRASKA, LYING SOUTHWESTERLY OF THE UNION PACIFIC RAILROAD COMPANY RIGHT-OF-WAY, TOGETHER WITH PART OF THE NW 1/4 OF SAID SECTION 35; TOGETHER WITH PART OF THE NE 1/4 OF THE SW 1/4 OF SAID SECTION 35.

*NE SW NW SE
SE SW NE SE
NW SW NE
NESW
SOWE*

SEE SHEET 2

NOTE:
DIMENSIONS IN PARENTHESIS
PERTAIN TO EASEMENTS.

- 50.00 FOOT WIDE EASEMENT GRANTED TO OMAHA PUBLIC POWER DISTRICT RECORDED IN MISC. BOOK 963 AT PAGE 541 OF THE DOUGLAS COUNTY RECORDS.
- 20.00 FOOT WIDE PERMANENT SEWER EASEMENT GRANTED TO THE CITY OF OMAHA RECORDED IN MISC. BOOK 659 AT PAGE 307 OF THE DOUGLAS COUNTY RECORDS.
- 20.00 FOOT WIDE PERMANENT SEWER EASEMENT GRANTED TO SANITARY & IMPROVEMENT DISTRICT NO. 342 RECORDED IN MISC. BOOK 821 AT PAGE 699 OF DOUGLAS COUNTY RECORDS.
- 130.00 FOOT WIDE SEWER AND DRAINAGE EASEMENT GRANTED TO THE CITY OF OMAHA RECORDED IN MISC. BOOK 475 AT PAGE 411 OF THE DOUGLAS COUNTY RECORDS.
- LINEAR TRAIL CORRIDOR EASEMENT GRANTED TO THE CITY OF OMAHA (SEE RECORDED DOCUMENT)
- 120.00 FOOT WIDE DRAINAGE EASEMENT GRANTED TO THE CITY OF OMAHA (SEE RECORDED DOCUMENT)
- DRAINAGE EASEMENT GRANTED TO PAPIO-MISSOURI RIVER NATURAL RESOURCES DISTRICT. (SEE RECORDED DOCUMENT)
- 50.00 FOOT WIDE INGRESS AND EGRESS EASEMENT (SEE RECORDED DOCUMENT)

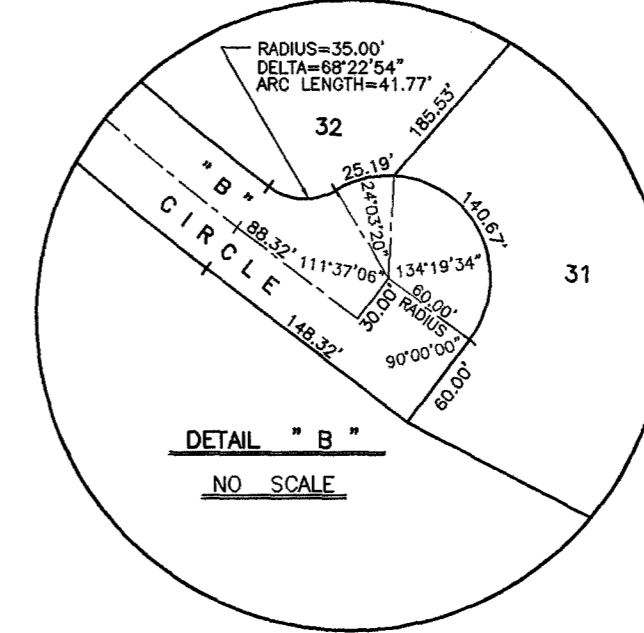
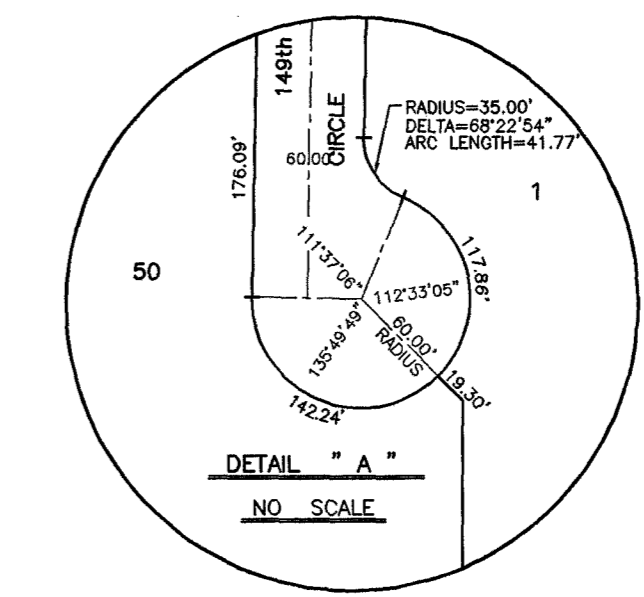

| CURVE INFORMATION | | | | |
|-------------------|----------|---------|------------|-----------|
| CURVE | RADIUS | TANGENT | ARC LENGTH | DELTA |
| 1 | 300.00' | 150.13' | 278.40' | 53°10'11" |
| 2 | 300.00' | 99.89' | 192.84' | 36°49'49" |
| 3 | 200.83' | 65.25' | 126.18' | 36°00'00" |
| 4 | 220.00' | 112.10' | 207.35' | 54°00'00" |
| 5 | 1431.81' | 50.00' | 99.96' | 4°00'00" |
| 6 | 225.00' | 225.00' | 353.43' | 90°00'00" |
| 7 | 275.00' | 121.73' | 229.21' | 47°45'18" |

NOTE: THERE SHALL BE NO DIRECT VEHICULAR ACCESS ONTO 144th STREET OVER THE EAST LINES OF LOTS 20, 21 AND OUTLOT "A".

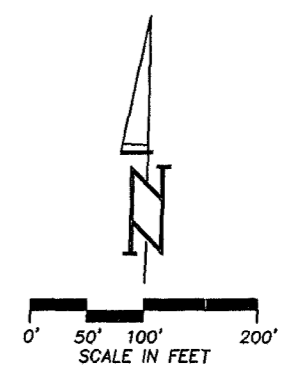
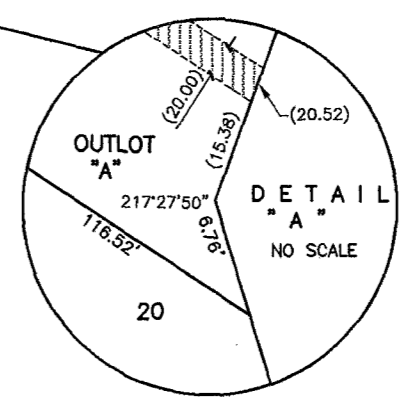

U N P L A T T E D

NO 01'30" W
2,298.19'

SW CORNER OF THE SE 1/4 OF SECTION 35, T15N, R11E OF THE 6TH P.M., DOUGLAS COUNTY, NEBRASKA.

50.00 FOOT WIDE "F" STREET RIGHT-OF-WAY DEDICATION

NOTE: THERE SHALL BE NO DIRECT VEHICULAR ACCESS ONTO "F" STREET OVER THE SOUTH LINES OF LOTS 1, 2, 26, 25, 23, 22, AND 21.

(POINT OF BEGINNING)

SE CORNER OF THE EAST 1/2 OF SECTION 35, T15N, R11E OF THE 6TH P.M., DOUGLAS COUNTY, NEBRASKA. (COMMENCING POINT)

ALTECH BUSINESS PARK

FINAL PLAT

2 THOMPSON, DRESSEN & DORNER, INC.
Consulting Engineers & Land Surveyors

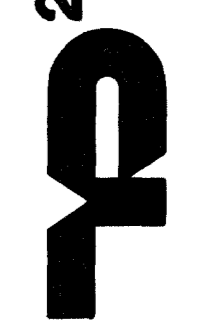

423-122

A423122A.DWG





ALTECH BUSINESS PARK

A CLUSTER SUBDIVISION

LOTS 1 THRU 50, INCLUSIVE & OUTLOTS A, B, C AND D

BEING A PLATTING OF PART OF THE EAST 1/2 OF SECTION 35, T15N, R11E OF THE 6TH P.M., DOUGLAS COUNTY, NEBRASKA LYING SOUTHWESTERLY OF THE UNION PACIFIC RAILROAD COMPANY RIGHT-OF-WAY, TOGETHER WITH PART OF THE NW 1/4 OF SAID SECTION 35; TOGETHER WITH PART OF THE NE 1/4 OF THE SW 1/4 OF SAID SECTION 35.

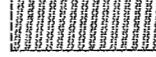
NOTE:
DIMENSIONS IN PARENTHESIS
PERTAIN TO EASEMENTS.

-  ACCESS EASEMENT GRANTED TO PAPIO-MISSOURI RIVER NATURAL RESOURCES DISTRICT. (SEE RECORDED DOCUMENT)
-  SANITARY SEWER EASEMENT GRANTED TO SANITARY AND IMPROVEMENT DISTRICT NUMBER 422 (SEE RECORDED DOCUMENT)
-  STORM SEWER AND DRAINAGE EASEMENT GRANTED TO SANITARY AND IMPROVEMENT DISTRICT NUMBER 422 (SEE RECORDED DOCUMENT)
-  PEDESTRIAN EASEMENT GRANTED TO SANITARY AND IMPROVEMENT DISTRICT NUMBER 422 (SEE RECORDED DOCUMENT)

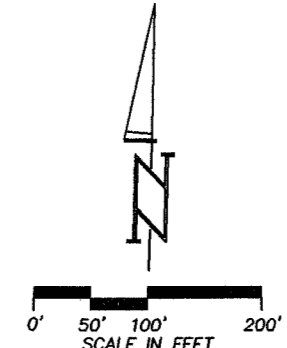

Handwritten notes:
NE NW
SE SW
NE SW
SW NE
SE SE
NE NW

NOTE: THERE SHALL BE NO DIRECT VEHICULAR ACCESS ONTO 144th STREET OVER THE EAST LINES OF LOTS 20, 21 AND OUTLOT "A".

SE CORNER OF THE EAST 1/2 OF SECTION 35, T15N, R11E OF THE 6TH P.M., DOUGLAS COUNTY, NEBRASKA. (COMMENCING POINT)

NOTE: THERE SHALL BE NO DIRECT VEHICULAR ACCESS ONTO "F" STREET OVER THE SOUTH LINES OF LOTS 1, 2, 26, 25, 23, 22, AND 21.

SEE SHEET 2

U N I O N P A C I F I C R A I L R O A D R I G H T - O F - W A Y



ALTECH BUSINESS PARK

FINAL PLAT

2 THOMPSON, DREESSEN & DORNER, INC.
Consulting Engineers & Land Surveyors
10836 OLD MILL ROAD
OMAHA, NE 68154
(402) 330-8860



423-122

ALTECH BUSINESS PARK

LOTS 1 THRU 50, INCLUSIVE & OUTLOTS A, B, C AND D

BEING A PLATTING OF PART OF THE EAST 1/2 OF SECTION 35, T15N, R11E OF THE 6TH P.M., DOUGLAS COUNTY, NEBRASKA. LYING SOUTHWESTERLY OF THE UNION PACIFIC RAILROAD COMPANY RIGHT-OF-WAY, TOGETHER WITH PART OF THE NW 1/4 OF SAID SECTION 35; TOGETHER WITH PART OF THE NE 1/4 OF THE SW 1/4 OF SAID SECTION 35.

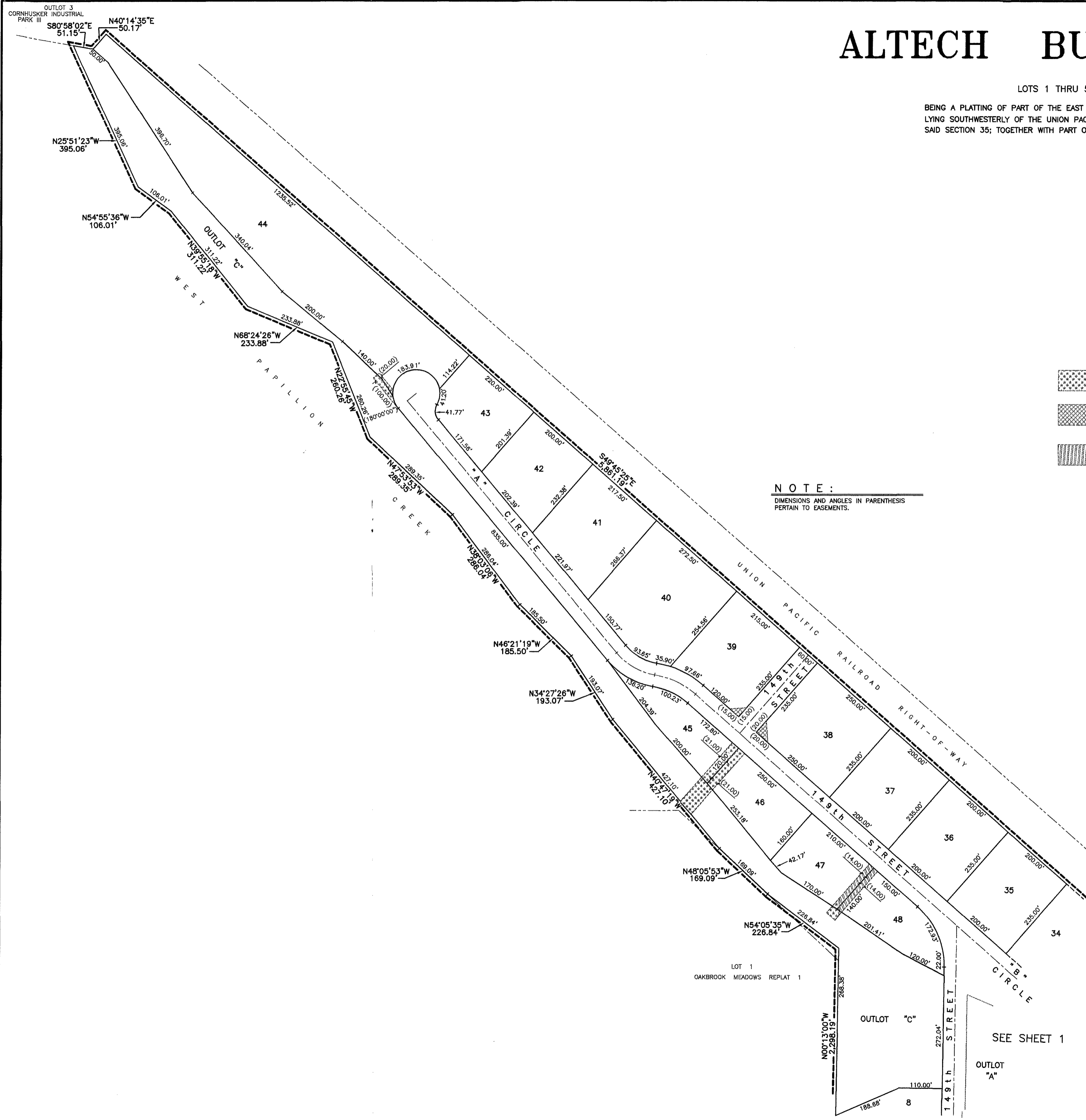

- STORM SEWER AND DRAINAGE EASEMENT GRANTED TO THE CITY OF OMAHA (SEE RECORDED DOCUMENT)
- PEDESTRIAN EASEMENT GRANTED TO THE CITY OF OMAHA (SEE RECORDED DOCUMENT)
- STORM SEWER AND DRAINAGE EASEMENT GRANTED TO SANITARY AND IMPROVEMENT DISTRICT NUMBER 422 (SEE RECORDED DOCUMENT)

NOTE:
DIMENSIONS AND ANGLES IN PARENTHESIS PERTAIN TO EASEMENTS.

| |
|---------------------|
| AS SHOWN |
| DATE: JAN. 23, 1998 |
| DRAWN BY: BAR |
| CHECKED BY: DHN |
| REVISION: |

ALTECH BUSINESS PARK

FINAL PLAT

THOMPSON, DREESSEN & DORNER, INC.
Consulting Engineers & Land Surveyors
10836 OLD MILL ROAD
OMAHA, NE 68154
(402) 330 - 8860



423-122