

78-576

PROJECT NO. _____

BOOK 530 TRACT NO. 139 PAGE 139

EASEMENT

THIS INDENTURE, made this 11 day of October, 1973,

between DEVELCO, a Nebraska Partnership,
hereinafter referred to as "Grantor(s)", and the City of Omaha, Nebraska, a Municipal Corporation,
hereinafter called "City",

WITNESSETH:

That said Grantor(s) in consideration of the sum of One and No/100-----

----- Dollars (\$1.00) and other valuable consideration, to Grantor(s) in hand paid by said City, the receipt whereof is hereby acknowledged does or do hereby grant, sell, convey and confirm unto said City and its assigns forever, a sewer and drainage easement for the right to use, construct, build, lay, maintain, repair and construct sanitary or storm sewer pipe or drainage way for the passage of sewer water and sewage or storm water, together with all appurtenances, wires, lines, poles, structures, and other applicable equipment pertaining to any sewer, or drainage facility, in, through, over and under the parcel of land described as follows, to-wit:

A portion of Lots 3 and 4; Cornhusker Industrial Park III, a subdivision as surveyed, platted and recorded in Douglas County, Nebraska described as follows: Commencing at the Southeast corner of said Lot 3; thence N 41°13'18" E (Assumed bearing) on the Easterly line of said Lot 3, 365.32 feet to the point of beginning; thence N 48°46'45"W, 30.00 feet; thence N 41°13'15" E, 25.00 feet; thence S 48°46'45" E, 60.00 feet; thence S 41°13'15" W, 25.00 feet; thence N 48°46'45" W, 30.00 feet to the point of beginning.

No. buildings, improvements, or structures, shall be placed in, on, over or across said easements by undersigned, his or their successors and assigns without express approval of the City of Omaha. Any trees, grass, and shrubbery placed on said easement shall be maintained by Grantor(s), his or their heirs, successors and assigns. Provided that said City agrees that the Grantor may pave or install other hard surface road over said easement way.

Said City shall cause any trench made on aforesaid realty to be properly refilled, and shall cause grass seed to be sown over said trench, and shall cause the premises to be left in a neat and orderly condition. This easement is also for the benefit of any contractor, agent, employee and representative of the City and any of said construction work.

Said Grantor(s) for himself or themselves and his or their heirs, executors and administrators does or do confirm with the said City and its assigns, that he or they, the Grantor(s) or are well seized in fee of the above described property and that he or they has or have the right to grant and convey this easement in the manner and form aforesaid, and that he or they will and his or their heirs, executors and administrators, shall warrant and defend this easement to said City and its assigns against the lawful claims and demands of all persons. This easement runs with the land.

The consideration recited includes damages for change of grade, if any, and any and all claims for damage arising from change of grade or grading are hereby waived.

IN WITNESS WHEREOF, said Grantor(s) has or have hereunto set his or their hand(s) and seal(s) the day and year first above written.

DEVELCO, A Nebraska Partnership

By [Signature]

By [Signature]

Corporate Seal:

BY _____ Name of Corporation President

ATTEST _____ Secretary

(Acknowledgment on Reverse Side hereon)

STATE OF NEBRASKA) SS
COUNTY OF DOUGLAS)

On this 17 day of October, 1973, before me, a Notary Public, in and for said County, personally came the above named:

1) ...
two partners of DEVELCO, a Nebraska Partnership,

who is (are) personally known to me to be the identical person(s) whose name(s) is (are) affixed to the above instrument and acknowledged the instrument to be his, her (their) voluntary act and deed for the purpose therein stated.

WITNESS my hand and Notarial Seal the date aforesaid.



[Signature]
Notary Public

My Commission Expires

STATE OF NEBRASKA) SS
COUNTY OF DOUGLAS)

On this _____ day of _____, 19____, before me, the undersigned, a Notary Public in and for said County, personally came _____

_____ President of _____
_____ a _____ Corporation,

and _____, Secretary of said Corporation, to me personally known to be the President and Secretary respectively of said Corporation and the identical persons whose names are affixed to the foregoing instrument, and acknowledged the execution thereof to be their respective voluntary act and deed as such officers and the voluntary act and deed of said Corporation, and the Corporate Seal of said Corporation to be thereto affixed by its authority.

WITNESS my hand and Notarial Seal at Omaha in said County the day and year last above written.

Notary Public

My Commission Expires

Union Pacific Railroad

CORNHUSKER Lot 3 BOOK 530 PAGE 141

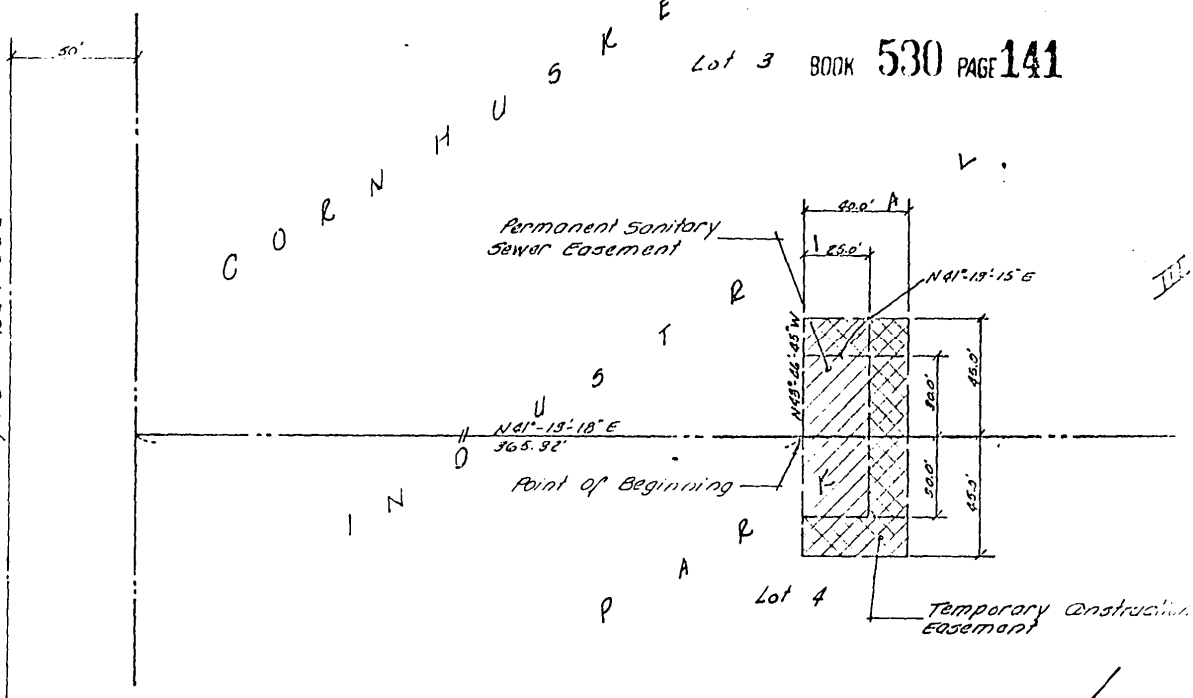

Legend

- Temporary Construction Easement [hatched box]
- Permanent Sanitary Sewer Easement [hatched box]

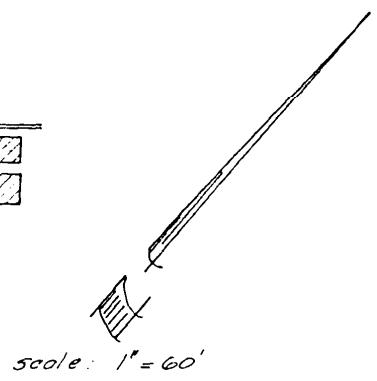

LEGAL DESCRIPTION

A Permanent Sanitary Sewer Easement located in Lots 3 and 4, Cornhusker Industrial Park III, a subdivision as surveyed, platted and recorded in Douglas County, Nebraska described as follows: Commencing at the Southeast corner of said Lot 3; thence N 41° 13' 18" E (Assumed bearing) on the Easterly line of said Lot 3, 365.32 feet to the point of beginning; thence N 48° 46' 45" W, 30.00 feet; thence N 41° 13' 15" E, 25.00 feet; thence S 48° 46' 45" E, 60.00 feet; thence S 41° 13' 15" W, 25.00 feet; thence N 48° 46' 45" W, 30.00 feet to the point of beginning.

Also, a Temporary Construction Easement, located in said Lots 3 and 4 described as follows: Commencing at the Southeast corner of said Lot 3; thence N 41° 13' 18" E (Assumed bearing) on the Easterly line of said Lot 3, 365.32 feet to the point of beginning; thence N 48° 46' 45" W, 45.00 feet; thence N 41° 13' 15" E, 40.00 feet; thence S 48° 46' 45" E, 90.00 feet; thence S 41° 13' 15" W, 40.00 feet; thence N 48° 46' 45" W, 45.00 feet to the point of beginning.

GRANTOR: _____

GRANTEE: _____

6

ENTERED IN NUMERICAL INDEX AND RECORDED IN THE REGISTER OF DEEDS OFFICE IN DOUGLAS COUNTY, NEBRASKA
 28 DAY OF 27th 23 AT 10:48 A.M. C. HAROLD OSTLER, REGISTER OF DEEDS 950