



THIS PAGE INCLUDED FOR  
INDEXING

PAGE DOWN FOR BALANCE OF INSTRUMENT



PLAT AND DEDICATION FOR STREET WIDENING

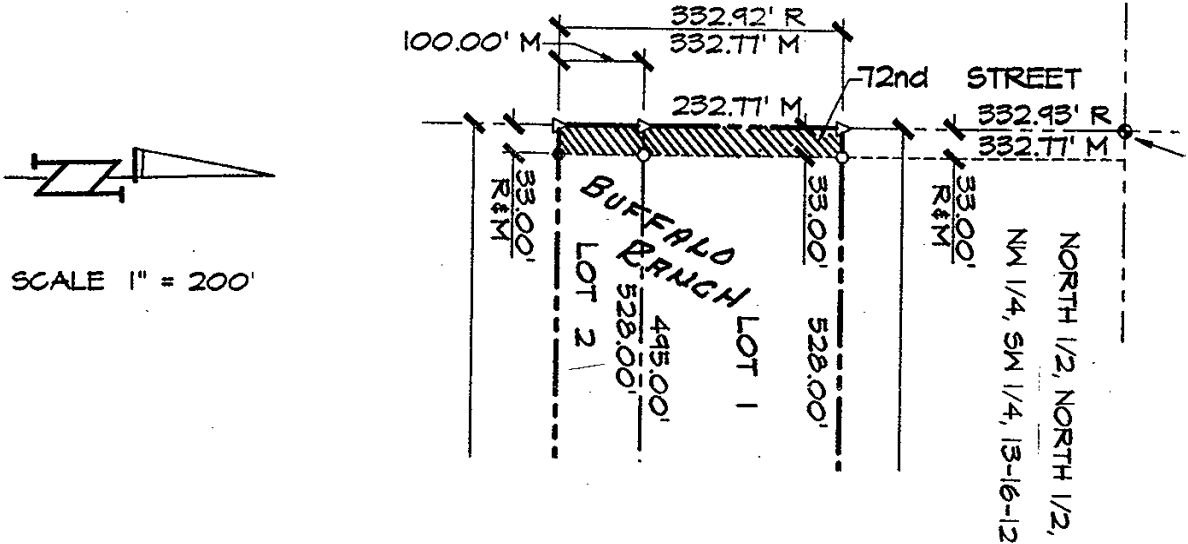

DEDICATION: KNOW ALL PERSONS BY THESE PRESENTS: That (we) (I) the undersigned Bill A. McKimney, sole owners of the 33.00 foot strip of land described below and embraced within the above plat and shown as additional right of way for 72nd Street hereby dedicate(s) to the public for public use the said 33.00 foot strip for street purposes to be hereafter known as 72nd Street

LEGAL DESCRIPTION: (attach additional sheets if needed)

The West 33.00 feet of Lots 1 and 2, Buffalo Ranch, a subdivision as surveyed, platted and recorded in Douglas County, Nebraska.

RECEIVED

Nov 8 1 48 PM '94

GEORGE J. WOODRUFF REGISTER OF DEEDS DOUGLAS COUNTY

13155 H  
 Fee 11.00  
 DEL  
 LEGAL POS 9  
 Comp  
 00-523  
 115

*Bill A. McKimney*  
 Owner's Signature

Bill A. McKimney  
 (Print or Type Name of Owner)

NOTARIAL SEAL AFFIXED  
 REGISTER OF DEEDS

Acknowledgment by Individual  
 State of Nebraska )  
 ) S.S.  
 County of Douglas )

On this 21<sup>st</sup> day of August, 19 94, before me a Notary Public, duly qualified and commissioned in and for said County and State, personally appeared Bill A. McKimney, who (are) (is) personally known to me to be the identical person(s) whose name(s) are affixed to the foregoing instrument and they acknowledged the signing of the same to be their voluntary act and deed.

TD 2 FILE NO. 20  
 BOOK 94-25 PAGES 48

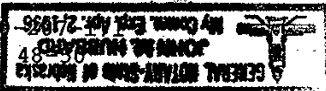

*George J. Woodruff*  
 Notary Public



(Mortgage Release-Corporate Acknowledgments and Approvals on reverse side)

(7/92)

MORTGAGE RELEASE: That \_\_\_\_\_ Mortgage(s) under Mortgage dated \_\_\_\_\_ day of \_\_\_\_\_, 19\_\_\_\_, recorded at \_\_\_\_\_ Book No. \_\_\_\_\_, Page No. \_\_\_\_\_, Mortgage Records, Douglas County, Nebraska covering \_\_\_\_\_ foot of land above described hereby consent to and approve of plat and dedication and release from said mortgage the \_\_\_\_\_ foot strip dedicated for street purposes without prejudice to the lien of mortgage on the remaining real estate.

State of Nebraska )  
County of Douglas ) s.s.

\_\_\_\_\_  
Mortgagee

On this \_\_\_\_\_ day of \_\_\_\_\_, 19\_\_\_\_, before me a Notary Public, duly qualified and commissioned in and for said County and State, personally appeared \_\_\_\_\_ who (are) (is) personally known to me to be identical person(s) whose name(s) are affixed to the foregoing instrument and they acknowledged the signing of the same to be their voluntary act and deed, and who is duly authorized to sign same.

Acknowledgment by Corporation

\_\_\_\_\_  
Notary Public

State of Nebraska )  
County of Douglas ) s.s.

On this \_\_\_\_\_ day of \_\_\_\_\_, 19\_\_\_\_, before me, the undersigned, a Notary Public in and for said county, personally came \_\_\_\_\_ president of the \_\_\_\_\_ Company, a corporation, to be personally known to be the president and identical person whose name is affixed to the above \_\_\_\_\_ and he/she acknowledged the execution thereof to be his/her voluntary act and deed as such officer, and the voluntary act and deed of said corporation.

Witness my hand and notarial seal at \_\_\_\_\_, in said county, the day and year last above written.

Acknowledgement by Corporation

\_\_\_\_\_  
Notary Public

State of Nebraska )  
County of Douglas ) s.s.

On this \_\_\_\_\_ day of \_\_\_\_\_, 19\_\_\_\_, before me, the undersigned, a Notary Public in and for said county, personally came \_\_\_\_\_ president of the \_\_\_\_\_ Company, a corporation, to be personally known to be the president and identical person whose name is affixed to the above \_\_\_\_\_ and he/she acknowledged the execution thereof to be his/her voluntary act and deed as such officer, and the voluntary act and deed of said corporation.

Witness my hand and notarial seal at \_\_\_\_\_, in said county, the day and year last above written.

\_\_\_\_\_  
Notary Public

APPROVALS: Above plat and dedication recommended for approval: by:

City Engineer [Signature] Date 9-28-94  
Planning Director [Signature] Date 9-26-94

This plat and dedication approved and accepted by the City Council of the CITY OF OMAHA this 25th day of October, 1994.

ATTEST [Signature] City Clerk **INTERIM** Mayor [Signature] City Council [Signature]

IMPRINTED SEAL REGISTER OF DEEDS