

# LAKESIDE VILLAGE SECOND ADDITION ADMINISTRATIVE PLAT

*Cam Jolte*  
REGISTER OF DEEDS  
2002 AUG -1 A 11:45  
LANCASTER COUNTY, NE

\$41.50  
INST NO 2002  
050663  
#3733

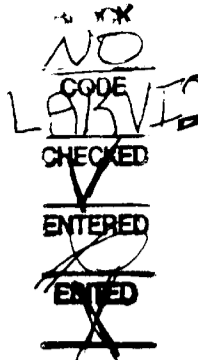

## SURVEYOR'S CERTIFICATE

I hereby certify that I have accurately surveyed and staked the foregoing Plat, to be known as Lakeside Village Second Addition.

A Legal Description of Outlot B of Lakeside Village, to the City of Lincoln, located in Section 21, Township 10 North, Range 6 East of the Sixth Principal Meridian, Lancaster County, Nebraska, and more particularly described by metes and bounds as follows:

Beginning at the Center One-Sixteenth Corner of the Southwest Quarter or Southwest Corner of Outlot B, Lakeside Village or the Northwest Corner of Western Manor Second Addition, all to the City of Lincoln, all located in Section 21, Township 10 North, Range 6 East of the Sixth Principal Meridian, Lancaster County, Nebraska; Thence N 00°00'27" E, (an assumed bearing), and on the West Line of the Northeast Quarter of the Southwest Quarter of said Section 21 and Outlot B of said Lakeside Village or the Easterly Right-of-way Line of U.S. Interstate Highway 80, a distance of 122.62 feet; Thence N 27°09'50" E, and on the West Line of Outlot B of said Lakeside Village or the East Right-of-way Line of said U.S. Interstate Highway 80, a distance of 1332.67 feet to the Northwest Corner of Outlot B or the Southwest Corner of Outlot A of said Lakeside Village; Thence S 16°01'39" E, and on the East Line of Outlot B or the West Line of Outlot A of said Lakeside Village and the West Right-of-way Line of Lakeside Drive, a distance of 547.42 feet; Thence N 73°25'51" E, and on the North Line of Outlot B of said Lakeside Village or the South Right-of-way Line of , a distance of 6.93 feet to a point on the West Right-of-Way of said Lakeside Drive said point is also on a curve to the left; Thence on a curve to the left and the East Line of Outlot B of said Lakeside Village or the West Right-of-way Line of said Lakeside Drive, having a radius of 368.62 feet, an arc length of 102.52 feet, and a central angle of 15°56'05", with a chord bearing of S 24°13'10" E, a chord distance of 102.19 feet to the East Corner of Outlot B or the Northeast Corner of Lot 2 of said Lakeside Village; Thence S 57°48'48" W, and on the East Line of Outlot B or the West Line of Lot 2 said Lakeside Village a distance of 83.64 feet; Thence S 00°17'41" E, and on the East Line of Outlot B or on the West Line of Lot 2 of said Lakeside Village, a distance of 67.06 feet to the East Corner of Outlot B or the Northeast Corner of Lot 1 of said Lakeside Village; Thence N 90°00'00" W, and on the South Line of Outlot B or the North Line of Lot 1 of said Lakeside Village a distance of 143.86 feet; Thence S 00°00'00" W, and on the East Line of Outlot B or the West Line of Lot 1 of said Lakeside Village a distance of 501.61 feet; Thence S 89°59'59" W, and on the South Line of Outlot B or the North Line of Lot 1 of said Lakeside Village a distance of 110.73 feet to the Point of Curvature; Thence on a curve to the right and on the South Line of Outlot B or the North Line of Lot 1 of said Lakeside Village, having a radius of 48.00 feet, an arc length of 21.55 feet, and a central angle of 25°43'25", with a chord bearing of N 77°08'18" W, a chord distance of 21.37 feet to a Point of Reverse Curvature; Thence on a curve to the left and the South Line of Outlot B or the North Line of Lot 1 of said Lakeside Village, having a radius of 32.75 feet, an arc length of 14.68 feet, and a central angle of 25°41'22", with a chord bearing of N 77°07'17" W, a chord distance of 14.56 feet to the Point of Tangency; Thence N 89°57'57" W, and on the South Line of Outlot B or the North Line of Lot 1 of said Lakeside Village a distance of 87.01 feet; Thence S 00°25'03" E, and on the East Line of Outlot B or the West Line of Lot 1 of said Lakeside Village, a distance of 83.15 feet to the Southeast Corner of Outlot B or the Southwest Corner of Lot 1 of said Lakeside Village and also said point is on the North Line of Western Manor Second Addition or the South Line of the Northeast Quarter of the Southwest Quarter of said Section 21; Thence S 89°34'57" W, and on the South Line of the Northeast Quarter of the Southwest Quarter of said Section 21 or the South Line of Outlot B of said Lakeside Village or the North Line of said Western Manor Second Addition a distance of 361.69 feet to the point of beginning and containing a calculated area of 479,322.11 square feet or 11.004 acres, more or less.

Permanent monuments have been placed at all lot corners and all other points required by the City of Lincoln Land Subdivision Ordinance, Title 26 of the Lincoln Municipal Code. All dimensions shown are in feet and decimals of a foot. All Curve dimensions are Chord distances unless otherwise noted.

Signed this 19th day of June, 2002.

*Mark A. Streit*  
Mark A. Streit L.S. No. 520  
Ross Engineering, Inc.  
201 8th Street, Suite 401  
Lincoln, Ne. 688508

## DEDICATION

The foregoing Plat of Lakeside Village Second Addition, being a subdivision of Outlot 'B', Lakeside Village to the City of Lincoln, located in the West Half of Section 21, Township 10 North, Range 6 East of the Sixth Principal Meridian, Lancaster County, Nebraska, more fully described in the Surveyor's Certificate is made with free consent and in accordance with the desires of the undersigned, sole owners and the easements shown thereon are hereby granted in perpetuity to the City of Lincoln, Nebraska, a municipal corporation the Alltel, Time-Warner Entertainment/Advance Newhouse,

**AQUILA**, their successors and assigns, to allow entry for the purpose of construction, reconstruction, replacement, repair, operation and maintenance of wires, cables, conduits, fixtures, poles, towers, pipes and equipment for the distribution of electricity, gas, telephone, cable television, wastewater collectors, storm drains, water mains, and all appurtenances thereto, over, upon, or under any easements shown on the foregoing Plat. The construction or location of any building or structure, excluding fences, over, upon, or under any easements shown thereon shall be prohibited.

The City of Lincoln, its successors or assign are hereby held harmless for the cost of replacement or damage to any improvement or vegetation over, upon or under any easement shown thereon.

WITNESS MY HAND this 19 day of June, 2002.

Owner of Record: Lakeside Partners, L.L.C., a Limited Liability Company, Outlot 'B', Lakeside Village to the City of Lincoln, located in the West Half of Section 21, Township 10 North, Range 6 East of the 6th P.M., Lancaster County, Nebraska.

*Craig G. Bauer*  
Craig G. Bauer, Manager  
Lakeside Partners, L.L.C., a Limited Liability Company

## ACKNOWLEDGMENT OF NOTARY

STATE OF NEBRASKA SS  
COUNTY OF LANCASTER SS

The foregoing instrument was acknowledged before me this 19 day of June, 2002, by Craig G. Bauer, Manager on behalf of Lakeside Partners, L.L.C. a limited liability company.

*Debra Parks* 12-23-05  
Notary Public Commission Expiration

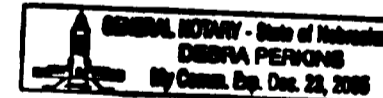

The Planning Director, pursuant to Section 26.11.015 of the LMC, hereby approves this Administrative Final Plat.

*Ray J. Miller* JULY 30, 2002  
Planning Director Date

## APPROVAL

## LIEN HOLDER CONSENT AND SUBORDINATION

The undersigned, holder of that certain lien against the real property described in the plat known as Lakeside Village Second Addition, (hereinafter "Plat"), said lien being recorded in the Office of the Register of Deeds of Lancaster County, Nebraska as Instrument No. 99-65102 and 99-65103, (hereinafter "Lien"), does hereby consent to the dedication of and subordinate the Lien to any utility (sewer, water, electrical, cable TV, telephone, natural gas) easements, or streets, or roads, pedestrian way easements, and access easements and relinquishments of access, dedicated to the public, all as shown on the Plat, but not otherwise. The undersigned confirms that it is the holder of the Lien and has not assigned the Lien to any other person.

Wells Fargo Bank Nebraska, N.A., successor in interest to National Bank of Commerce Trust and Savings Association, by reason of consolidation and name change.

By: *Mark L. Gerner*  
(Person Signing on behalf of the bank, title)

## ACKNOWLEDGMENT OF NOTARY

STATE OF NEBRASKA SS  
COUNTY OF LANCASTER SS

The foregoing instrument was acknowledged before me this 15th day of July, 2002, by (Person Signing on behalf of the bank, title).

*Cara B. Dahlquist* 1-15-2004  
Notary Public Commission Expiration

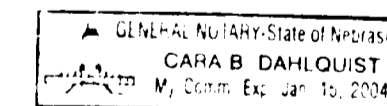

# LAKESIDE VILLAGE SECOND ADDITION ADMINISTRATIVE PLAT

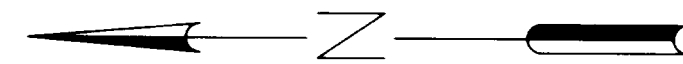

Scale: 1" = 100'

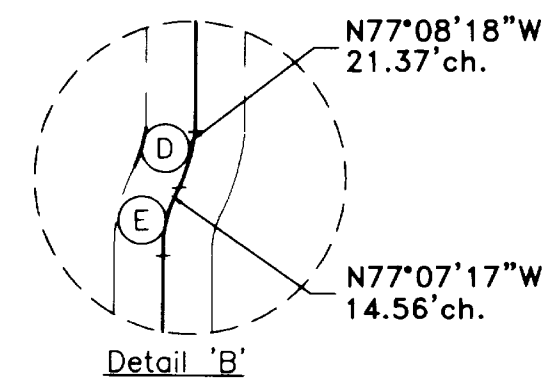
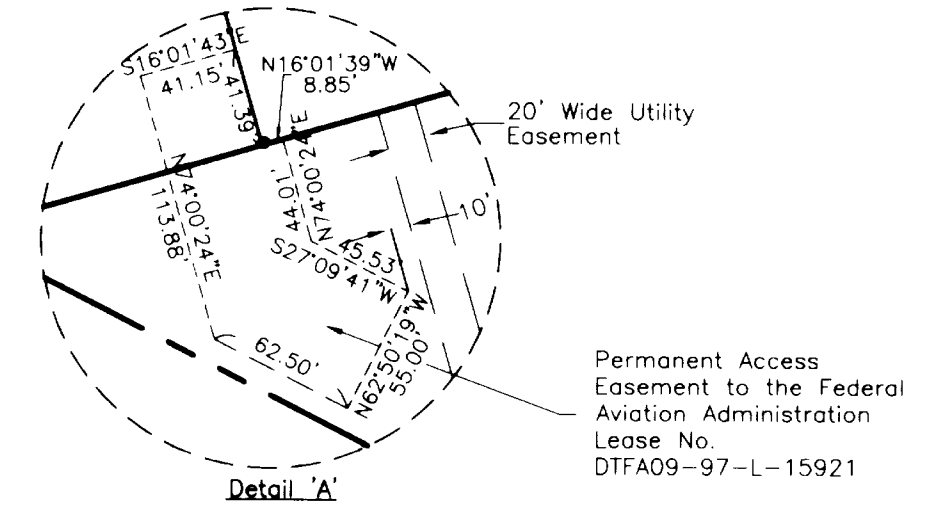

## LEGEND

- ⊙ = Section & 1/4 Corner
- = Corner Found
- = Corner Set, (5/8"x30" Rebar)
- (P) = Platted Distance
- (M) = Measured Distance
- (D) = Deeded Distance
- (R) = Recorded Distance

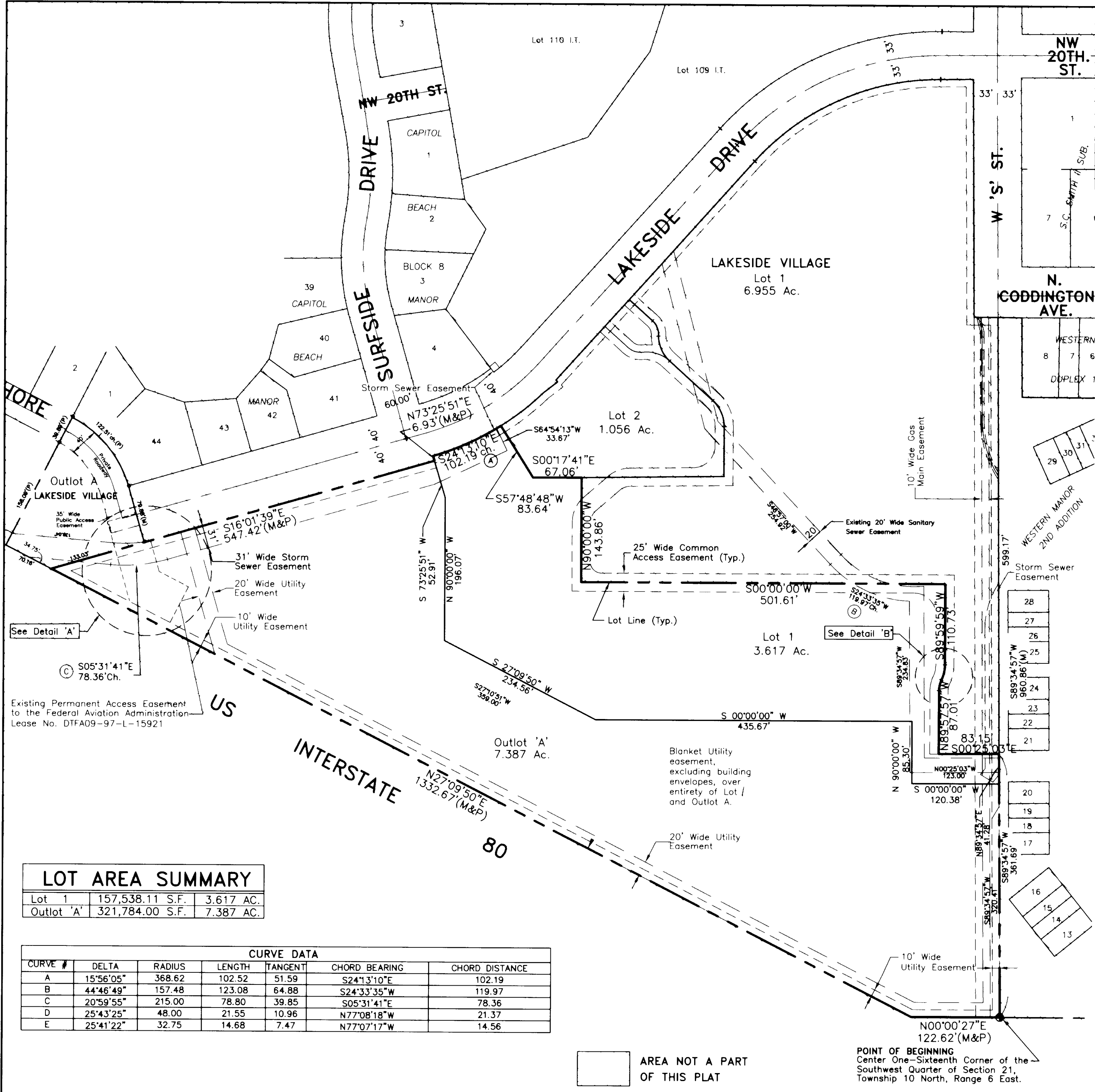

### LOT AREA SUMMARY

Lot 1	157,538.11 S.F.	3.617 AC.
Outlot 'A'	321,784.00 S.F.	7.387 AC.

### CURVE DATA

CURVE #	DELTA	RADIUS	LENGTH	TANGENT	CHORD BEARING	CHORD DISTANCE
A	15°56'05"	368.62	102.52	51.59	S24°13'10"E	102.19
B	44°46'49"	157.48	123.08	64.88	S24°33'35"W	119.97
C	20°59'55"	215.00	78.80	39.85	S05°31'41"E	78.36
D	25°43'25"	48.00	21.55	10.96	N77°08'18"W	21.37
E	25°41'22"	32.75	14.68	7.47	N77°07'17"W	14.56

AREA NOT A PART OF THIS PLAT

POINT OF BEGINNING  
Center One-Sixteenth Corner of the  
Southwest Quarter of Section 21,  
Township 10 North, Range 6 East.