



Parcel Information	
Parcel ID	760010730
Links	Photo #1 Sketch #1
Map Number	3689-00-0-10100-186-0004
Cadastral #	004-022-0030
Current Owner	CLEMENTS, COURTNEY
Mailing Address	805 NORMAN AVENUE CRETE, NE 68333-
Situs Address	805 NORMAN AVENUE
Tax District	5
Tax ID	004-022-0030
School District	CRETE 2
Neighborhood	1300
Property Class	Single Family
Lot Width x Depth	77 x 122
Legal Description	CRETE CITY S 1/2 OF LOT 9 & ALL OF LOTS 10-11-12 BLK. 186

Assessed Values				
Year	Total	Land	Improvements	Outbuildings
2018	\$93,305	\$14,670	\$78,635	\$0

2018 Tax Information	
Taxes	\$1,964.84
Tax Levy	2.192326

2018 Tax Levy	
Description	Rate
AGRICULTURE SOC.	0.010994
CRETE 2	1.053421
CRETE 2 BOND (2013)	0.196197
CRETE CITY	0.491534
CT HOUSE BOND (2015)	0.010555
ED SERV. UNIT #6	0.015669
HISTORICAL SOC.	0.001029
JAIL BOND	0.017892
LOWER B BLUE NRD	0.024231
SALINE COUNTY	0.280104
SE COMM COLLEGE	0.090700

5 Year Sales History				
Date	Book/Page	# Parcels	Grantor	Price
2016/09/13	419-700	1	SCRIBNER/NATHAN D &~JENNIFER R	\$102,500.00



Property Classification			
Status:	Improved	Location:	Urban
Property Class:	Single Family	City Size:	5,001-12,000
Zoning:	Single Family	Lot Size:	<10,000 sq. ft.

Land Information				
<u>Lot Width</u>	<u>Lot Depth</u>	<u>Value Method</u>	<u># of Units</u>	<u>Lot Value</u>
77	122	Sq ft.	9394	14670

Historical Valuation Information							
<u>Year</u>	<u>Billed Owner</u>	<u>Land</u>	<u>Impr</u>	<u>Outbldg</u>	<u>Total</u>	<u>Taxable</u>	<u>Taxes</u>
2018	CLEMENTS/COURTNEY	\$14,670	\$78,635	\$0	\$93,305	\$93,305	\$1,964.84
2017	CLEMENTS/COURTNEY	\$14,670	\$74,890	\$0	\$89,560	\$89,560	\$1,879.24
2016	CLEMENTS/COURTNEY	\$14,670	\$71,325	\$0	\$85,995	\$85,995	\$1,826.96
2015	SCRIBNER/NATHAN D & JENNIFER R	\$14,670	\$71,325	\$0	\$85,995	\$85,995	\$1,852.48
2014	SCRIBNER/NATHAN D & JENNIFER R	\$14,670	\$71,325	\$0	\$85,995	\$85,995	\$1,911.90

Residential Datasheet			
Type	Single-Family	Heat Type	100 % WARM & COOLED AIR &
Quality / Condition	30 Average / 40 Good	Foundation	Concrete Block/8
Arch. Type		Slab Area	0 sq. ft
Year Built	1917	Crawl Area	0 sq. ft
Actual Age	102	Basement Area	931sq. ft.
Ext. Wall 1	100 % SIDING	Min Finish	419 sq. ft
Ext. Wall 2		Rec Finish	
Base Area	1,027 sq. ft	Part Finish	419 sq. ft
Total Area	1,570 sq. ft	Bedrooms	4
Style 1		Bathrooms	1
Style 2		Garage Type	
Roof Type	COMP SHINGLES	Garage Area	

Miscellaneous Improvements		
<u>Improvement</u>	<u>Year</u>	<u>Units</u>
PATIO		144
garage cf/av		216
ROOFED PORCH OPEN		84
ROOFED SLAB/PATIO		114
WD DECK PINE		116

Photo/Sketch

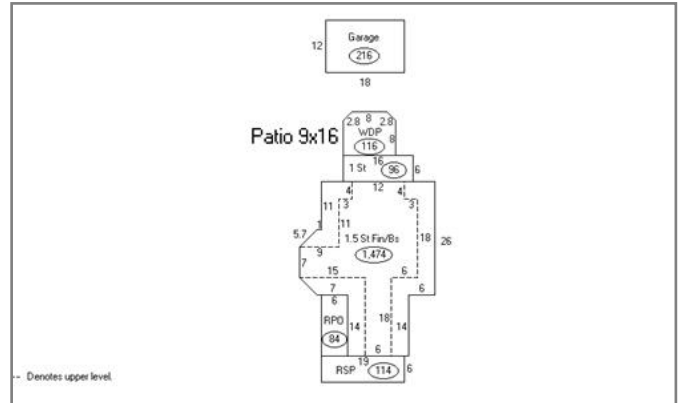

Tax Statement

Served by WEBSERVER-TWO

Saline County

 Step 4 of 8

Perm ID 760010730	Name CLEMENS/COURTNEY 805 NORMAN AVENUE CRETE, NE 68333-	Legal CRETE CITY S 1/2 OF LOT 9 & ALL OF LOTS 10-11-12 BLK. 186 805 \ NORMAN AVENUE
-----------------------------	--	--



[Levy Graph](#) 
[Value Graph](#) 
[Tax Graph](#) 

Year	Statement	Value	Tax	Exemption	Net Tax	Balance Due
2018	001359	\$ 93,305	\$ 2,045.54	- \$ 80.70	\$ 1,964.84	\$ 1,964.84
2017	001339	\$ 89,560	\$ 1,958.00	- \$ 78.76	\$ 1,879.24	\$ 0.00
2016	001336	\$ 85,995	\$ 1,903.98	- \$ 77.02	\$ 1,826.96	\$ 0.00
2015	007558	\$ 85,995	\$ 1,933.40	- \$ 80.92	\$ 1,852.48	\$ 0.00
2014	007529	\$ 85,995	\$ 1,973.42	- \$ 61.52	\$ 1,911.90	\$ 0.00
2013	007515	\$ 85,995	\$ 2,073.22	- \$ 56.74	\$ 2,016.48	\$ 0.00
2012	007518	\$ 78,665	\$ 1,757.82	- \$ 56.24	\$ 1,701.58	\$ 0.00
2011	007503	\$ 78,665	\$ 1,784.08	- \$ 59.24	\$ 1,724.84	\$ 0.00
2010	007523	\$ 78,665	\$ 1,725.38	- \$ 62.08	\$ 1,663.30	\$ 0.00
2009	000554	\$ 78,665	\$ 1,732.50	- \$ 64.68	\$ 1,667.82	\$ 0.00
2008	000552	\$ 80,645	\$ 1,745.82	- \$ 69.46	\$ 1,676.36	\$ 0.00
2007	003977	\$ 80,645	\$ 1,746.02	- \$ 67.12	\$ 1,678.90	\$ 0.00
2006	002224	\$ 83,365	\$ 1,804.40	\$ 0.00	\$ 1,804.40	\$ 0.00
2005	002656	\$ 79,265	\$ 1,693.84	\$ 0.00	\$ 1,693.84	\$ 0.00
2004	002812	\$ 79,265	\$ 1,691.30	\$ 0.00	\$ 1,691.30	\$ 0.00
2003	001035	\$ 76,010	\$ 1,613.40	\$ 0.00	\$ 1,613.40	\$ 0.00
2002	000871	\$ 68,790	\$ 1,441.82	\$ 0.00	\$ 1,441.82	\$ 0.00
2001	000662	\$ 63,940	\$ 1,364.04	\$ 0.00	\$ 1,364.04	\$ 0.00
2000	001477	\$ 63,940	\$ 1,390.98	- \$ 19.52	\$ 1,371.46	\$ 0.00
1999	001691	\$ 42,355	\$ 887.18	\$ 0.00	\$ 887.18	\$ 0.00
1998	003050	\$ 42,355	\$ 882.38	\$ 0.00	\$ 882.38	\$ 0.00
1997	003446	\$ 33,919	\$ 820.26	\$ 0.00	\$ 820.26	\$ 0.00
1996	007418	\$ 33,919	\$ 870.40	\$ 0.00	\$ 870.40	\$ 0.00

The information provided in this site is the most recent and most accurate data available. All information contained herein is for informational purposes only. MIPS Inc does not warrant that such information is accurate and error free. This information is provided on an "as is" basis without warranties of any kind, either expressed or implied, including, but not limited to, the implied warranties of merchantability or fitness for a particular purpose. MIPS Inc shall not be liable for any direct, indirect, incidental, special or consequential damages arising out of the use of such information or the inability to use such information. MIPS also is not, nor shall be party to or subject to any warranty or any breach of any kind. The User acknowledges and agrees that the use of such information is at the sole risk of the User.

Copyright © 2004 Nebraska Association of County Officials. All rights reserved.