

E A S E M E N T

This Agreement made this 15 day of May, 1967, between H & H LEASING CO., a Nebraska corporation, hereinafter called "Grantor" and SANITARY AND IMPROVEMENT DISTRICT NO. 129 OF DOUGLAS COUNTY, NEBRASKA, hereinafter called "District".

W I T N E S S E T H :

WHEREAS, Grantor is contemplating the construction of a sanitary sewer in California and 102nd Streets as shown and more particularly described on Exhibit "A" attached hereto which by reference is made a part hereof; and

WHEREAS, said sewer, in the future, may serve property other than the property of the Grantor.

NOW, THEREFORE, in consideration of the permission to construct such sewer, the Grantor does hereby grant, convey and confirm to the District, Permanent Easements on, over, under, and in and across the real estate described on Exhibit "A" attached hereto and made a part hereof, said easement being described on said Exhibit "A", for the purpose of changing, repairing, inspecting, maintaining and reconstructing said sewer or any part thereof.

District agrees to make good or cause to be made good to the owner or owners of the property in which said sewer is to be constructed, any and all damage that may be done by reason of negligent changes, alterations, maintenance, inspection, repairs or reconstruction in the way of damage to trees, grounds, buildings, or other improvements abutting thereon, including crops, vines and gardens; provided, however, that this provision does not apply to any of the aforesaid located in, on, over or across said easement or any part thereof.

This Agreement shall be binding on the successors and assigns of the respective parties hereto.

IN WITNESS WHEREOF, the parties hereto, for themselves, their successors and assigns, have caused the due execution hereof as of the day and year first above written.

H & H LEASING CO., a corporation

ATTEST:

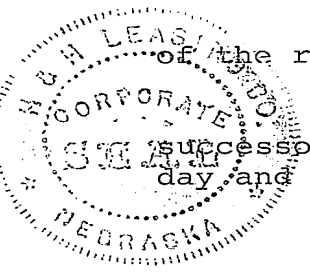

James J. Fitzgerald, Jr.
Secretary

By *W.D. Harford*
President

STATE OF NEBRASKA)
) ss.
COUNTY OF DOUGLAS)

On this 15 day of May, 1967, before me, the undersigned, a Notary Public in and for said County, personally came *W.D. Harford, Jr.*, President of H & H Leasing Co., a Nebraska Corporation, and *James J. Fitzgerald, Jr.*, Secretary of said corporation, to me personally known to be the President and Secretary respectively of said Corporation and the identical persons whose names are affixed to the foregoing Easement and acknowledged the execution thereof to be their respective voluntary act and deed as such officers and the voluntary act and deed of said Corporation, and the Corporate Seal of said corporation to be thereto affixed by its authority.

WITNESS my hand and Notarial Seal the day and year last above written.

William E. Camp
Notary Public

My Commission expires the 28 day of August, 1968

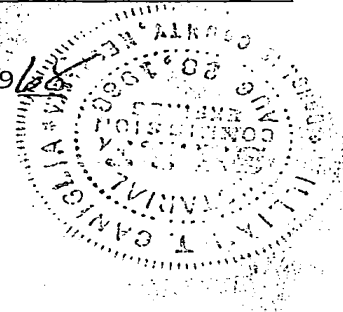

Approved as to Form:

City Attorney

EXHIBIT "A"

SANITARY SEWER EASEMENT

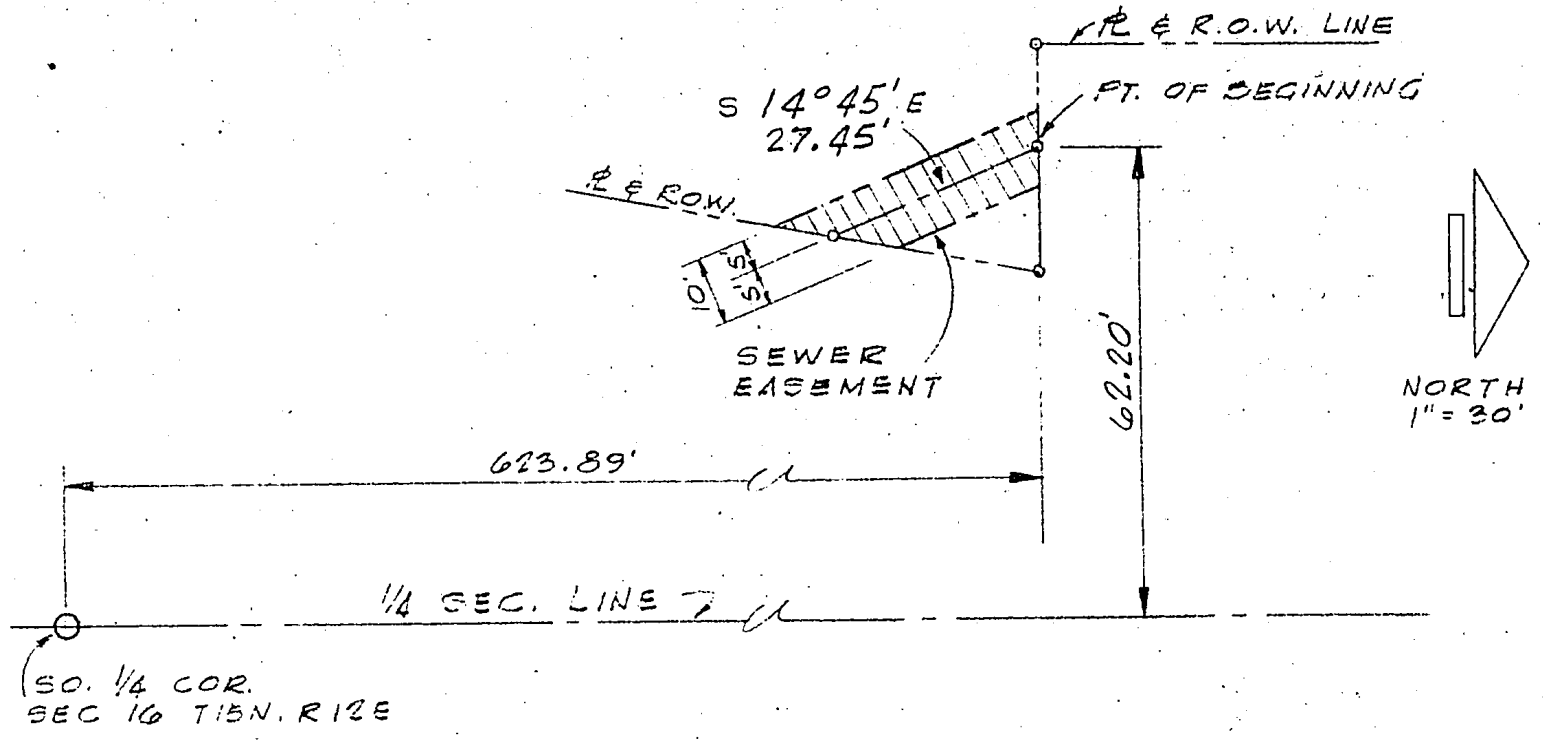

A tract of land ten feet wide whose boundaries are parallel to and a distance of five feet from either side of a sewer centerline, located in the East Half (E 1/2) of the Southwest Quarter (SW 1/4) of Section 16, Township 15 North, Range 12 East of the Sixth Principal Meridian in Douglas County, Nebraska, which centerline is more particularly described as follows:

Beginning at a point located 623.89 feet North and 62.20 feet West of the South Quarter Corner of Said Section 16; thence South 14° 45' East for a distance of 27.45 feet.

RECEIVED

1967 JUL 12 PM 2 45

THOMAS J. O'CONNOR
REGISTER OF DEEDS
DOUGLAS COUNTY, NEBR.

THE STATE OF NEBRASKA
Douglas County
Listed in Deeds and Mortgages
for Record in the office of the Register of
Deeds of said County and recorded in
Book 451 at page
Page 155

Thomas J. O'Connor
Register of Deeds

By Wm. C. Cunningham Deputy
MAIL 300 4th Street Beaty
N. 16-15-12 P.M.D.
Compass 475

16-15-12