

82-157

GRANT OF EASEMENT
PERMANENT SEWER EASEMENT

This Indenture and Grant of Easement made this 14th day of June, 1973, between Industrial Five, a Partnership, hereinafter referred to as "Grantors", in favor of Sanitary and Improvement District No. 268 of Douglas County, Nebraska, hereinafter referred to as "SID", and its successors and assigns, including but not in limitation of the City of Omaha, Douglas County, Nebraska, a municipal corporation, hereinafter referred to as "City".

W I T N E S S E T H :

That said Grantors in consideration of the sum of One Dollar (\$1.00) and other valuable consideration, to Grantors in hand paid by said SID, the receipt whereof is hereby acknowledged, does or do hereby grant, sell, convey and confirm unto said SID and City and their assigns forever, the right to use, construct, build, lay, maintain, repair and reconstruct a sanitary or storm sewer pipe or both for the passage of water and sewage, together with all appurtenances, wires, lines, poles, structures, and other applicable equipment pertaining to any sewer, in, through, over and under the parcels of land described as follows, to-wit:

A 10 foot wide Permanent Sewer and Drainage Easement over the west 10 feet of Lot 36, Southwest Park, a platted and recorded subdivision in Douglas County, Nebraska;

A 20 foot wide Permanent Sewer and Drainage Easement over the south 20 feet of Lot 36, Southwest Park, a platted and recorded subdivision in Douglas County, Nebraska;

A 10 foot wide Permanent Sewer and Drainage Easement over the east 10 feet of Lot 35, Southwest Park, a platted and recorded subdivision in Douglas County, Nebraska;

A 10 foot wide Permanent Sewer and Drainage Easement over the east 10 feet of Lot 113, Southwest Park, a platted and recorded subdivision in Douglas County, Nebraska;

A 10 foot wide Permanent Sewer and Drainage Easement over the west 10 feet of Lot 114, Southwest Park, a platted and recorded subdivision in Douglas County, Nebraska;

A 10 foot wide Permanent Sewer and Drainage Easement over the west 10 feet of Lot 29, Southwest Park, a platted and recorded subdivision in Douglas County, Nebraska;

A 10 foot wide Permanent Sewer and Drainage Easement over the west 10 feet of Lot 28, Southwest Park, a platted and recorded subdivision in Douglas County, Nebraska;

A 20 foot wide Permanent Sewer and Drainage Easement over the southerly 20 feet of Lot 28, Southwest Park, a platted and recorded subdivision in Douglas County, Nebraska;

A 15 foot wide Permanent Sewer and Drainage Easement over the west 15 feet of Lot 19, Southwest Park, a platted and recorded subdivision in Douglas County, Nebraska;

A 15 foot wide Permanent Sewer and Drainage Easement over the east 15 feet of Lot 2, Southwest Park, a platted and recorded subdivision in Douglas County, Nebraska;

A 15 foot wide Permanent Sewer and Drainage Easement over the east 15 feet of Lot 1, Southwest Park, a platted and recorded subdivision in Douglas County, Nebraska;

A 15 foot wide Permanent Sewer and Drainage Easement over the north 15 feet of Lot 1, Southwest Pkar, a platted and recorded subdivision in Douglas County, Nebraska;

A 15 foot wide Permanent Sewer and Drainage Easement over the east 15 feet of Lot 50, Southwest Park, a platted and recorded subdivision in Douglas County, Nebraska;

A 15 foot wide Permanent Sewer and Drainage Easement over the east 15 feet of Lot 49, Southwest Park, a platted and recorded subdivision in Douglas County, Nebraska;

A 10 foot wide Permanent Sewer and Drainage Easement over the west 10 feet of Lot 99, Southwest Park, a platted and recorded subdivision in Douglas County, Nebraska;

A 10 foot wide Permanent Sewer and Drainage Easement over the east 10 feet of Lot 100, Southwest Park, a platted and recorded subdivision in Douglas County, Nebraska;

A 15 foot wide Permanent Sewer and Drainage Easement over the east 15 feet of Lot 51, Southwest Park, a platted and recorded subdivision in Douglas County, Nebraska;

A 15 foot wide Permanent Sewer and Drainage Easement over the east 15 feet of Lot 52, Southwest Park, a platted and recorded subdivision in Douglas County, Nebraska;

A 15 foot wide Permanent Sewer and Drainage Easement over the east 15 feet of Lot 53, Southwest Park, a platted and recorded subdivision in Douglas County, Nebraska;

A Permanent Sewer and Drainage Easement over part of Lot 20, Southwest Park, a platted and recorded subdivision in Douglas County, Nebraska, being more particularly described as follows: Beginning at the Northwest corner of said Lot 20; thence North $89^{\circ}49'25''$ East a distance of 387.63 feet; thence South $00^{\circ}10'35''$ East a distance of 140.53 feet; thence Westerly along a 125.00 foot radius curve to the left an arc distance of 14.89 feet; thence North $00^{\circ}10'35''$ West a distance of 111.43 feet; thence South $89^{\circ}49'25''$ West a distance of 357.63 feet; thence South $00^{\circ}10'35''$ East a distance of 25.00 feet; thence south $89^{\circ}49'25''$ West a distance of 15.00 feet; thence north $00^{\circ}00'51''$ East a distance of 55.00 feet to the point of beginning.

No buildings, improvements or structures, shall be placed, in, on, over or across said easements by undersigned, his or their successors and assigns without express approval of said SID and said City; provided, however, that a paved, macadam, rocked, asphalt or other hard surfaced street or parking lot, and trees, grass and shrubbery, may be installed within said easement by Grantor, his or their successors and assigns, and that in the event it becomes necessary to remove or replace said street, parking lot, trees, grass, or shrubbery, in order to repair or maintain said sewer line, the removal or repair of said street or parking lot shall be done at the expense of SID and its successors and assigns and said premises shall be restored by SID and its successors and assigns to the condition thereof before said removal or repair.

Said SID shall cause any trench made on aforesaid realty to be properly refilled, and shall cause grass seed to be sown over said trench, and shall cause the premises to be left in a neat and orderly condition.

This easement is also for the benefit of any contractor, agent, employee and representative of the SID and said City in any of said construction and work.

Said Grantors for himself or themselves and his or their heirs, executors and administrators does or do confirm with the said SID and City and their assigns, that he or they, the Grantors is or are well seized in fee of the above described property and that he or they has or have the right to grant and convey this easement in the manner and form aforesaid, and that he or they will, and his or their heirs, executors and administrators, shall warrant and defend this easement to said SID and City and their assigns against the lawful claims and demands of all persons. This easement runs with the land.

The consideration recited includes damages for change of grade, if any, and any and all claims for damages arising from change of grade or grading are hereby waived.

IN WITNESS WHEREOF, said Grantor(s) has or have hereunto set his or their hands and seal(s) the day and year first above written.

INDSTRUSTRIAL FIVE, A Partnership

By [Signature]
A Partner

By [Signature]
A Partner

STATE OF NEBRASKA)
) ss.
COUNTY OF DOUGLAS)

On this 14th day of June, 1973, before me, the undersigned, a Notary Public in and for said County, personally came Franklin R. Rogers and Roger D. Honey, Partners of Industrial Five, a Partnership, to me personally known to be Partners of Industrial Five, and the identical persons whose names are affixed to the foregoing instrument, and acknowledged the execution thereof to be their voluntary act and deed as such partners, and the voluntary act and deed of said partnership.

WITNESS my hand and Notarial Seal in said County the day and year first above written.

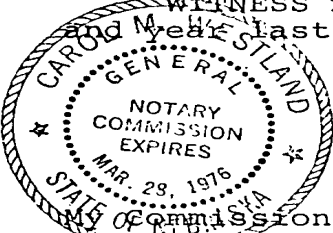

[Signature]
Notary Public

Commission Expires:
March 23, 1976

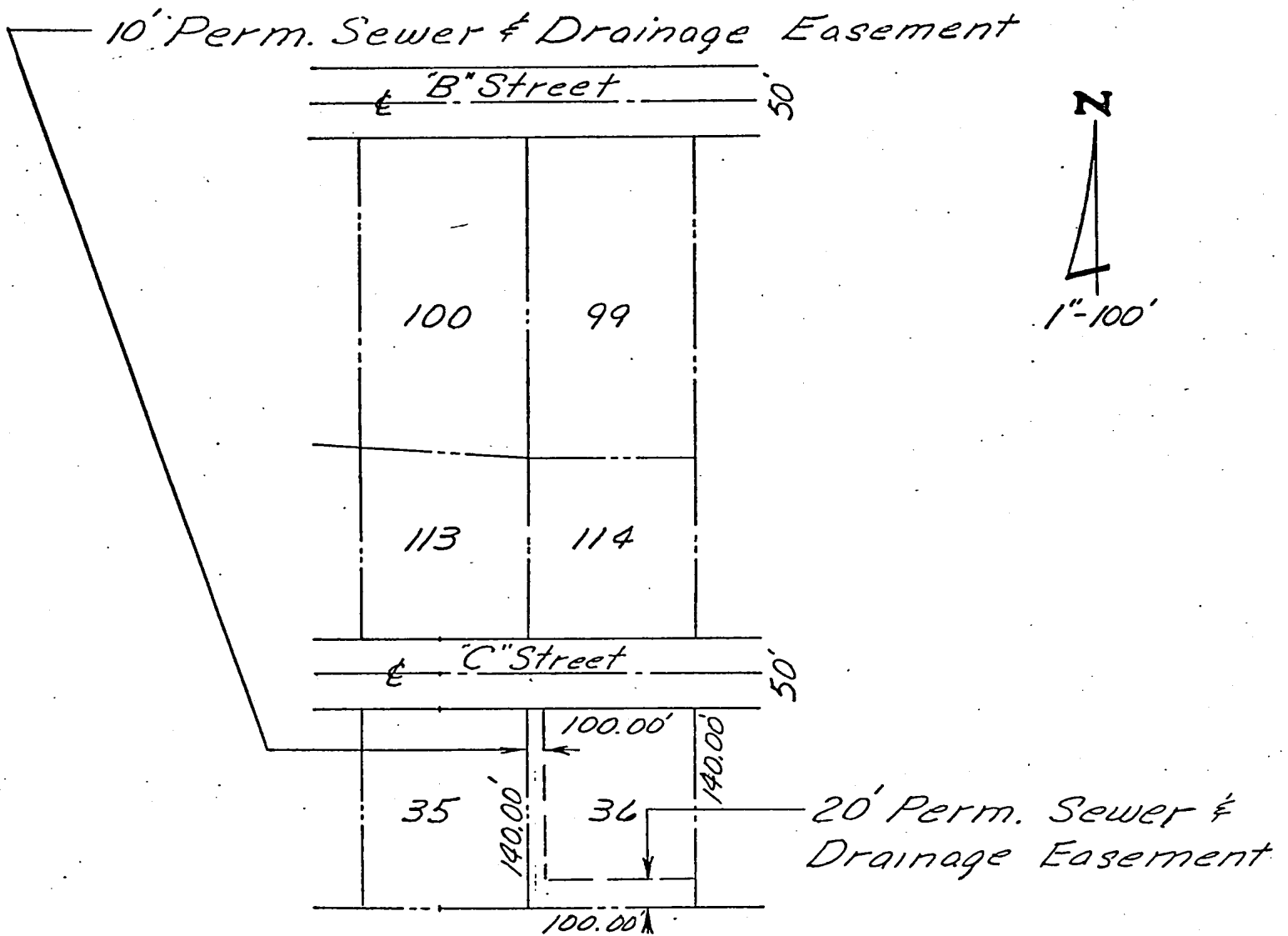

Legal Description: Lot 36, Southwest Park, a platted and recorded subdivision in Douglas County, Nebraska.

Permanent Sewer and Drainage Easement.

The West 10 feet and the South 20 feet of said Lot 36.

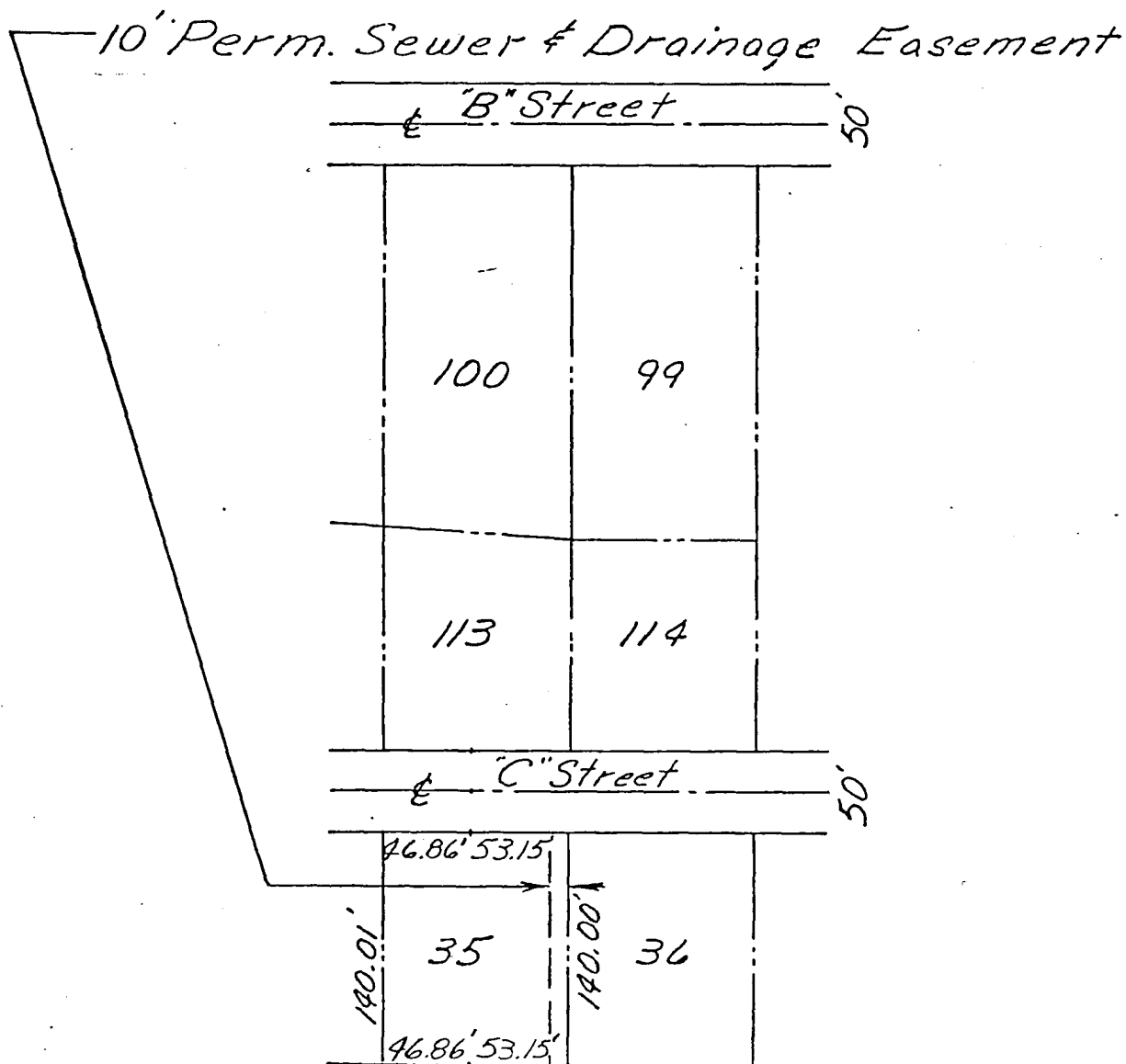

Legal Description : Lot 35, Southwest Park, a platted and recorded subdivision
in Douglas County, Nebraska.

Permanent Sewer and Drainage Easement

The East 10 feet of said Lot 35.

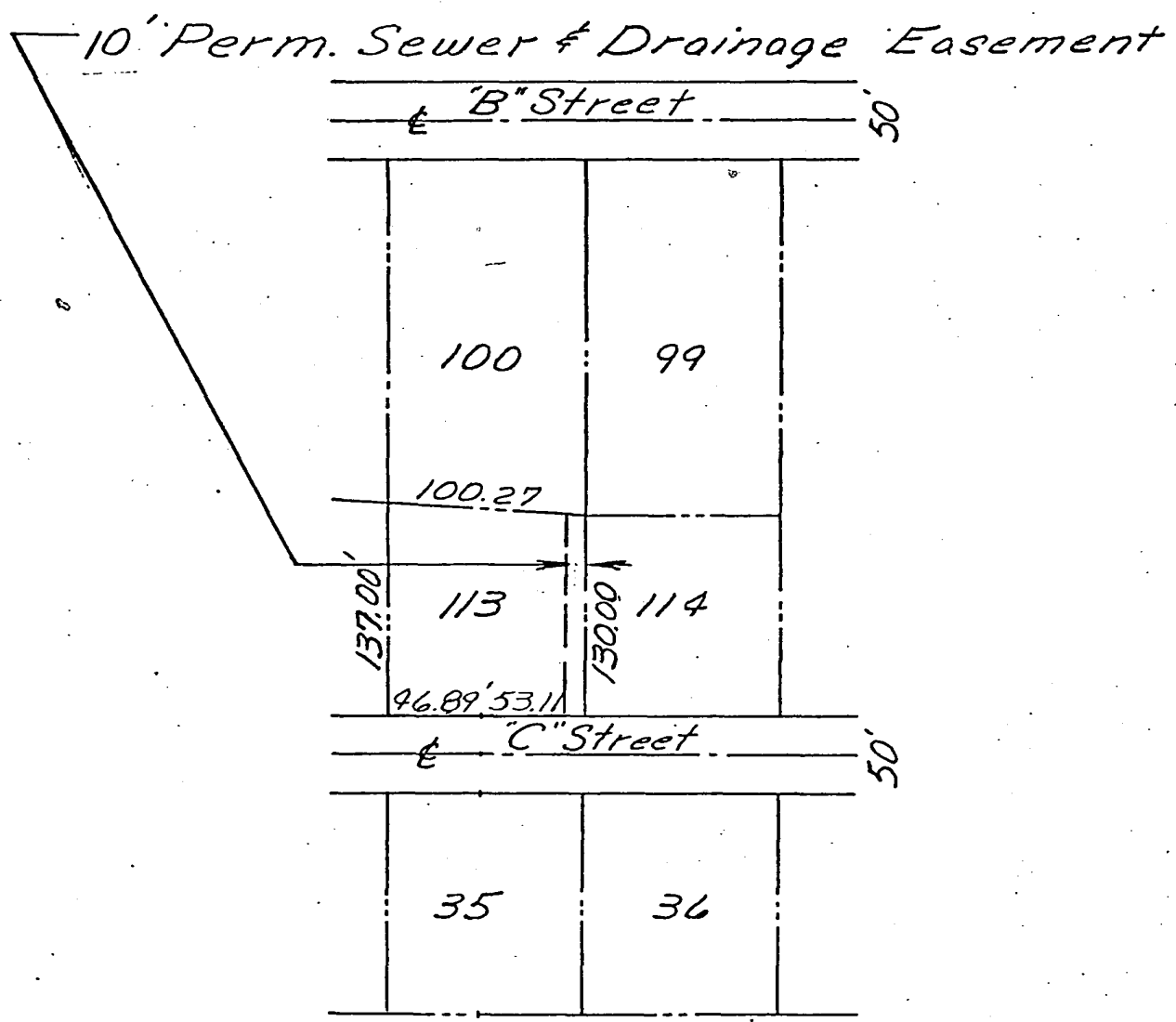

Legal Description: Lot 113, Southwest Park, a platted and recorded subdivision in Douglas County, Nebraska.

Permanent Sewer and Drainage Easement.

The East 10 feet of said Lot 113.

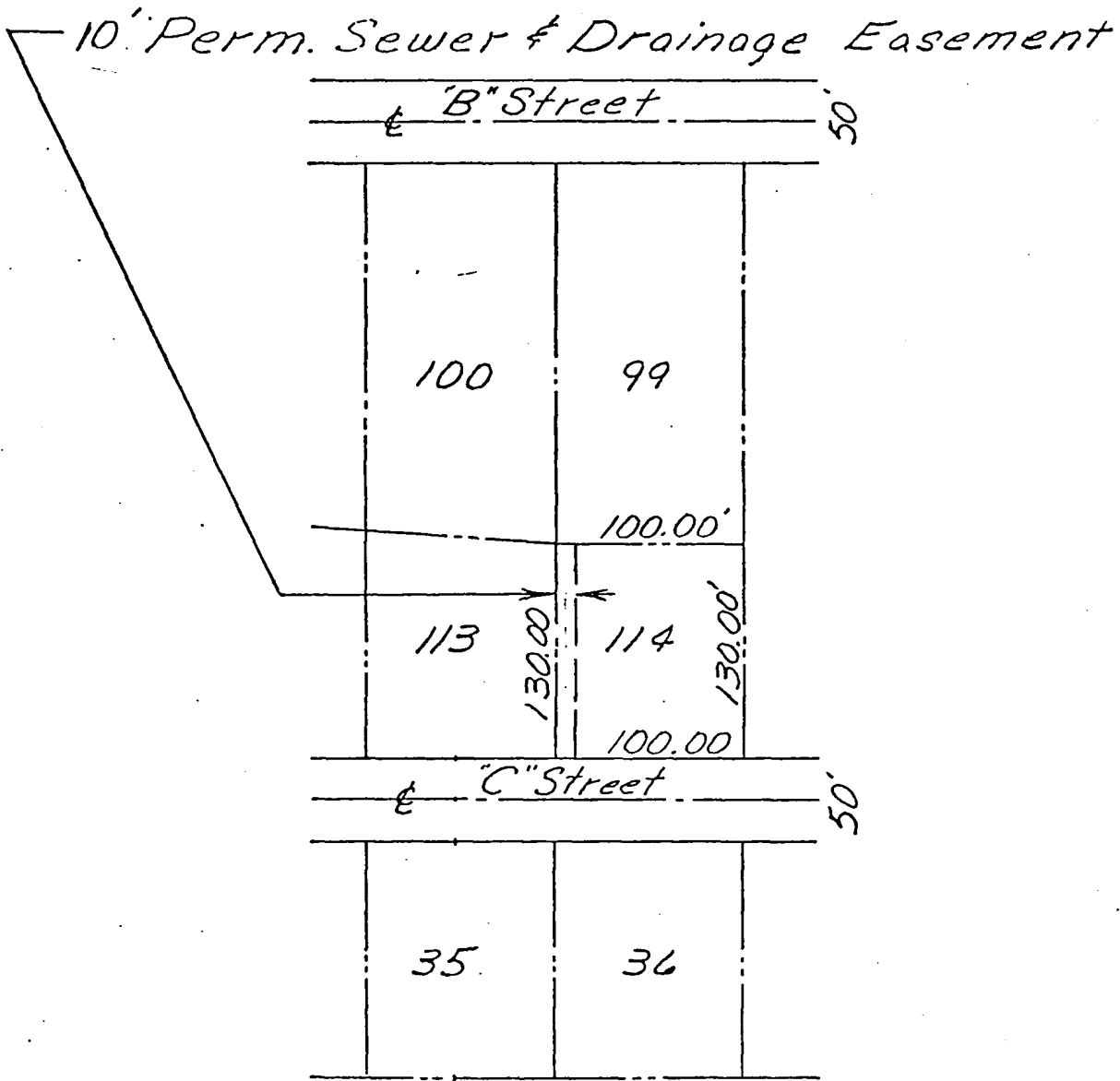

Legal Description: Lot 114, Southwest Park, a platted and recorded subdivision in Douglas County, Nebraska.

Permanent Sewer and Drainage Easement.

The West 10 feet of said Lot 114.

138th Street



10' Perm. Sewer & Drainage Easement

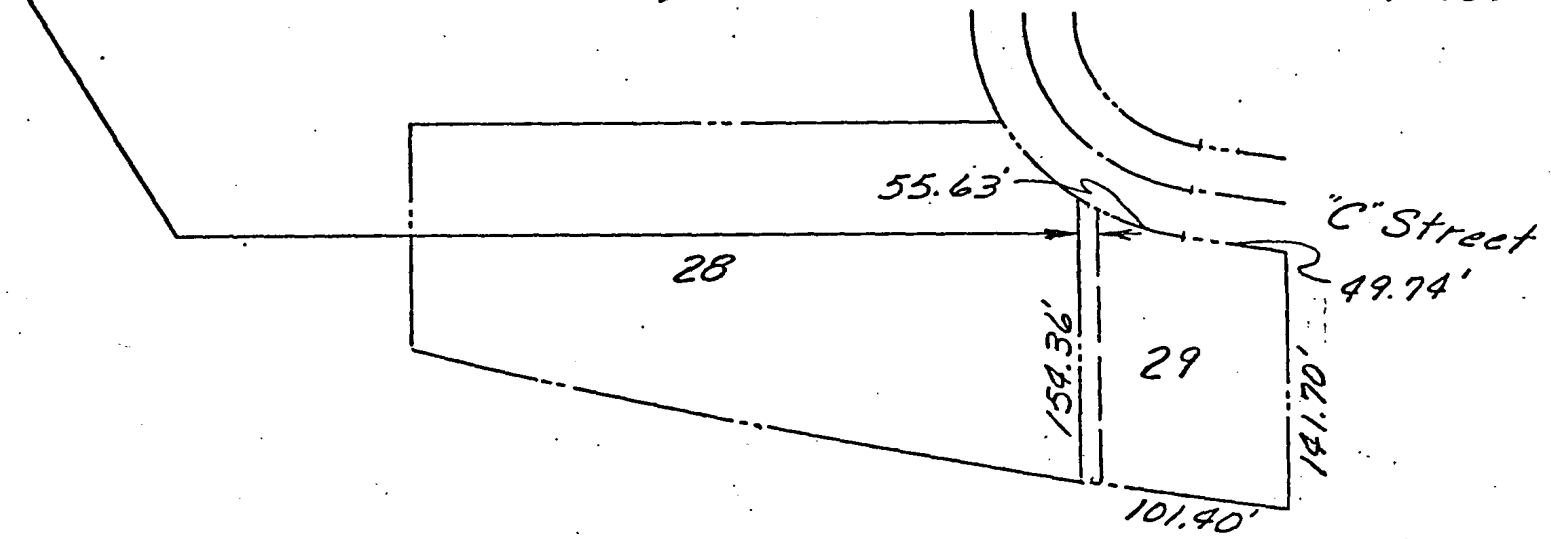

LEGAL DESCRIPTION

Lot 29, Southwest Park, a platted and recorded subdivision in Douglas County, Nebraska.

Permanent Sewer and Drainage Easement..

The West 10.00 feet of said Lot 29.

138th Street

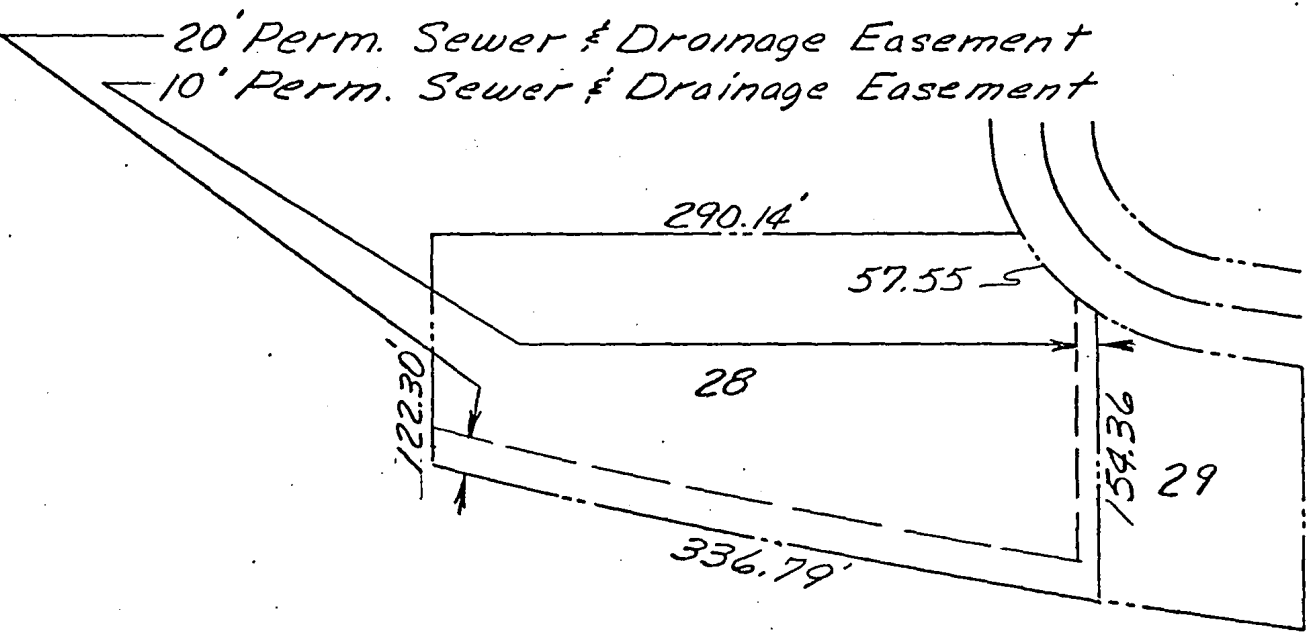
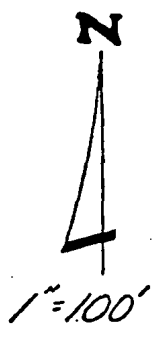

LEGAL DESCRIPTION

Lot 28, Southwest Park, a platted and recorded subdivision in Douglas County, Nebraska.

Permanent Sewer and Drainage Easement.

The West 10.00 feet and the Southerly 20.00 feet of said Lot 28.

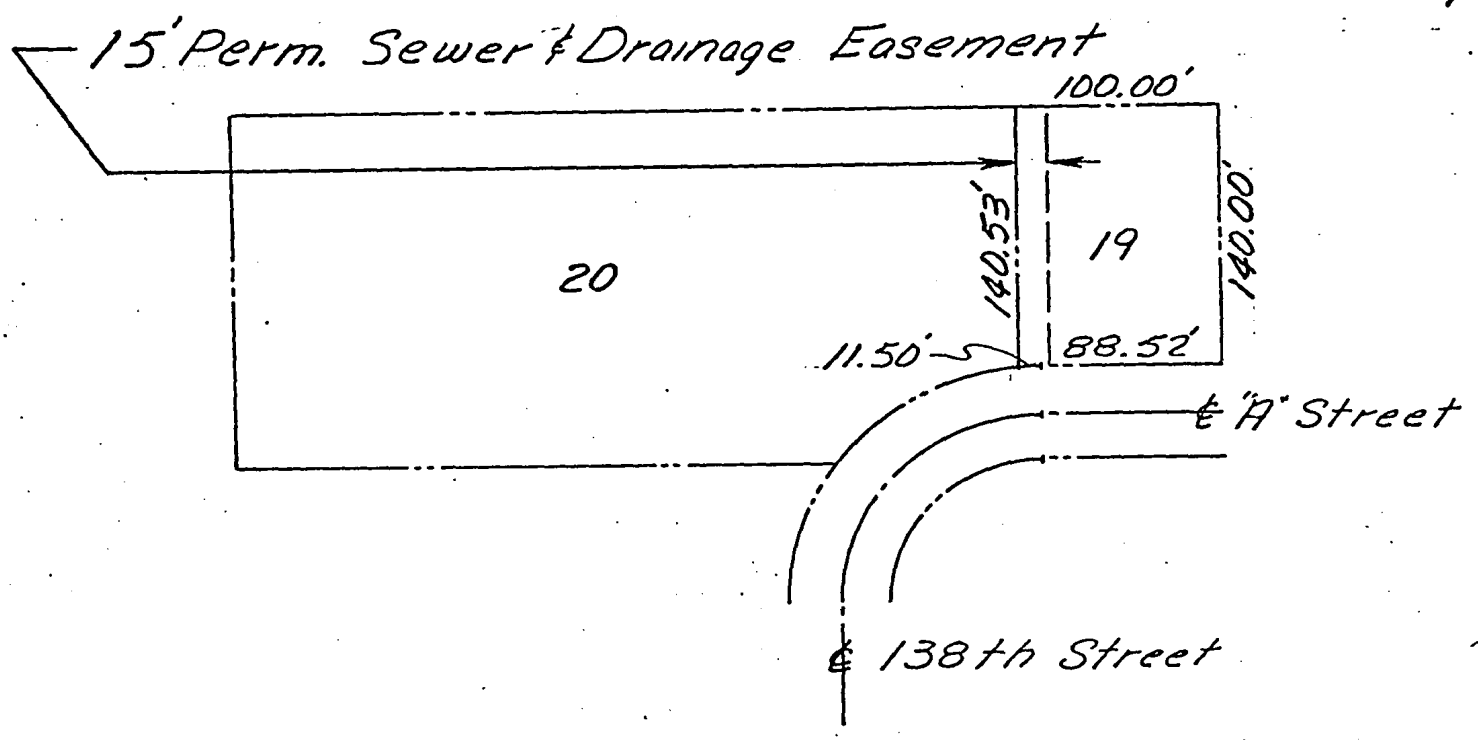

LEGAL DESCRIPTION

Lot 19, Southwest Park, a platted and recorded subdivision in Douglas County, Nebraska.

Permanent Sewer and Drainage Easement.

The West 15.00 feet of said Lot 19.



15' Perm. Sewer & Drainage Easement

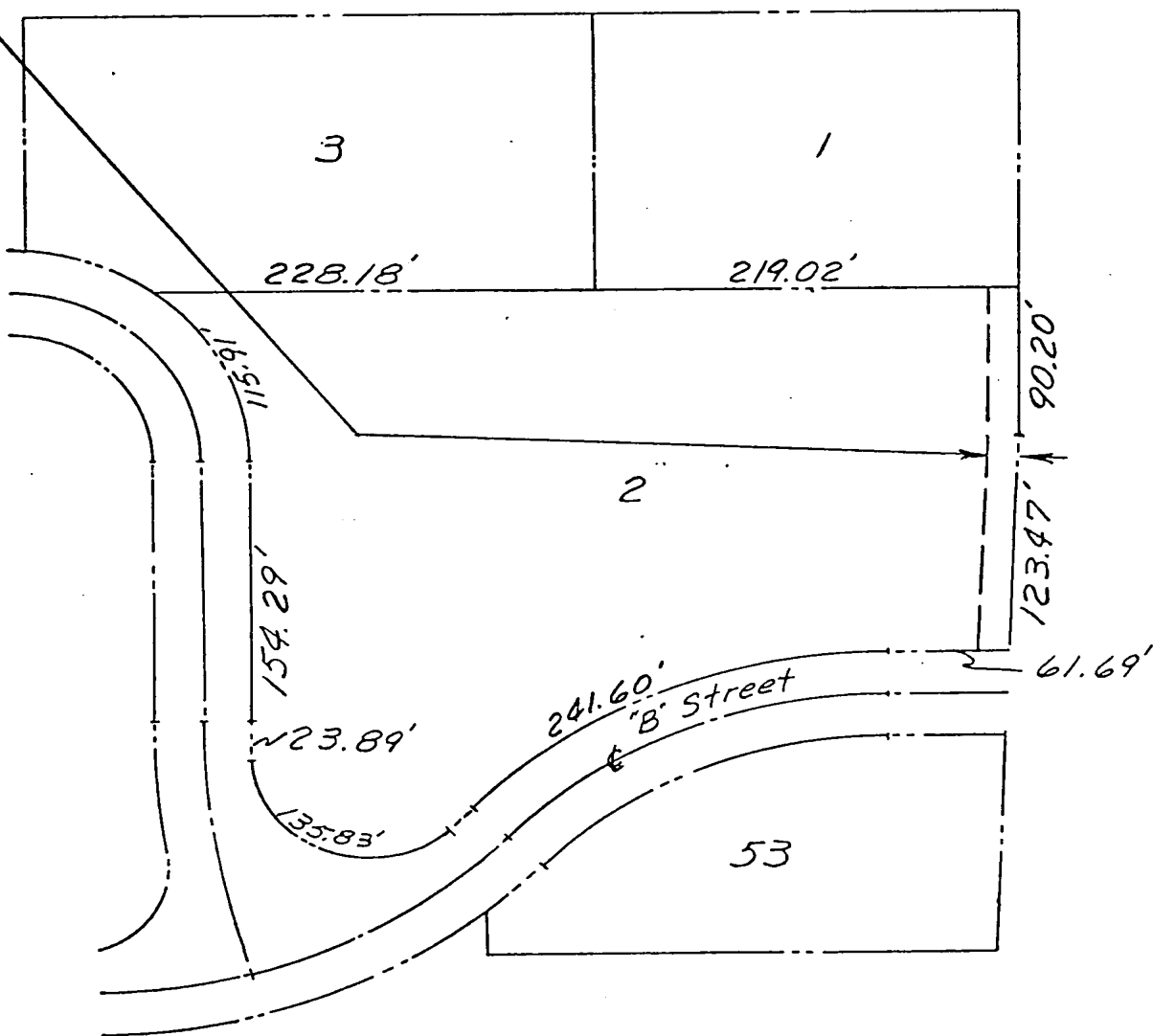

LEGAL DESCRIPTION

Lot 2, Southwest Park, a platted and recorded subdivision in Douglas County, Nebraska.

Permanent Sewer and Drainage Easement.

The East 15.00 feet of said Lot 2.



1"=100'

15' Perm. Sewer and Drainage Easement
15' Perm. Sewer and Drainage Easement

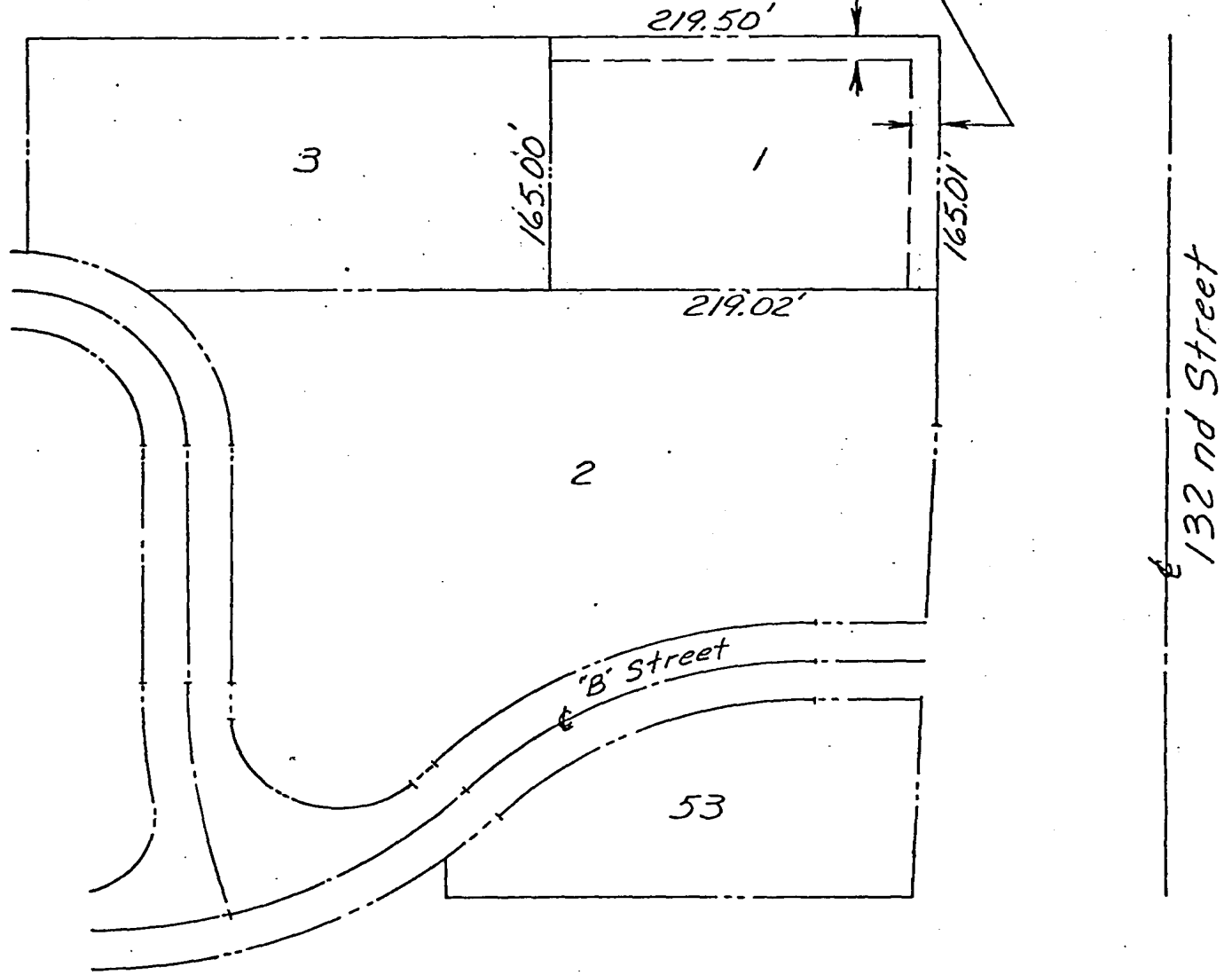

Legal Description - Lot 1, Southwest Park, a platted and recorded subdivision in Douglas County, Nebraska.

Permanent Sewer and Drainage Easement

The East 15 feet and the North 15 feet of said Lot 1.

15' Perm. Sewer & Drainage Easement

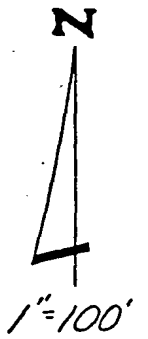
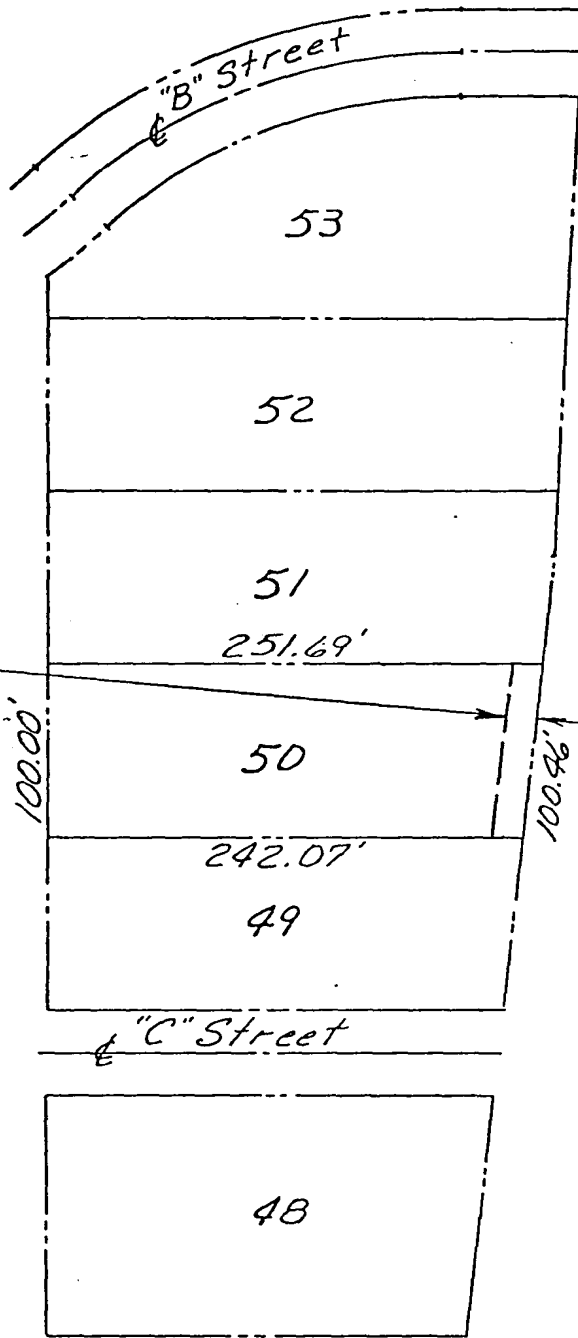

Legal Description - Lot 50, Southwest Park, a platted and recorded subdivision in Douglas County, Nebraska.

Permanent Sewer and Drainage Easement.

The East 15 feet of said Lot 50.

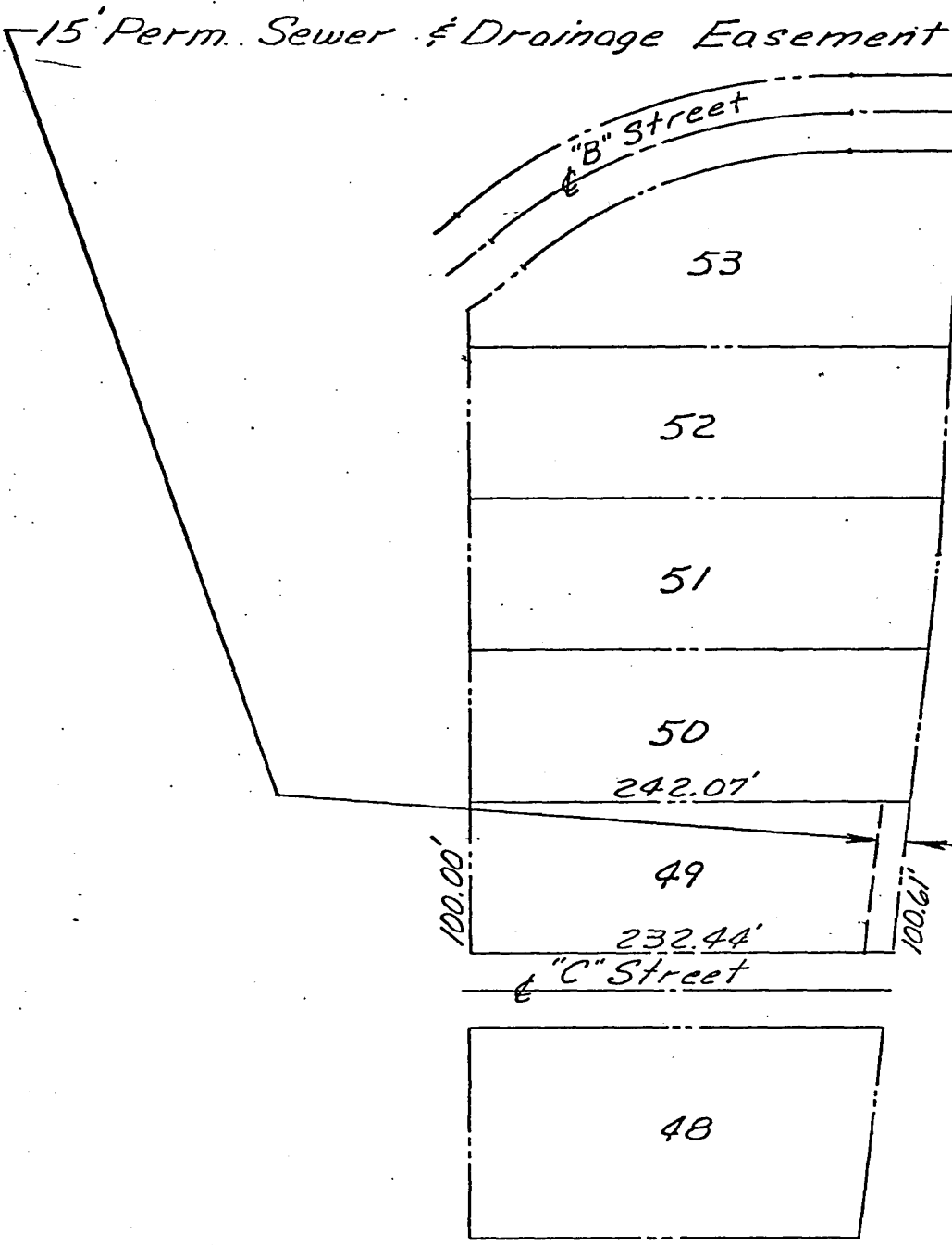

Legal Description - Lot 49, Southwest Park, a platted and recorded subdivision in Douglas County, Nebraska.

Permanent Sewer and Drainage Easement.

The East 15 feet of said Lot 49.

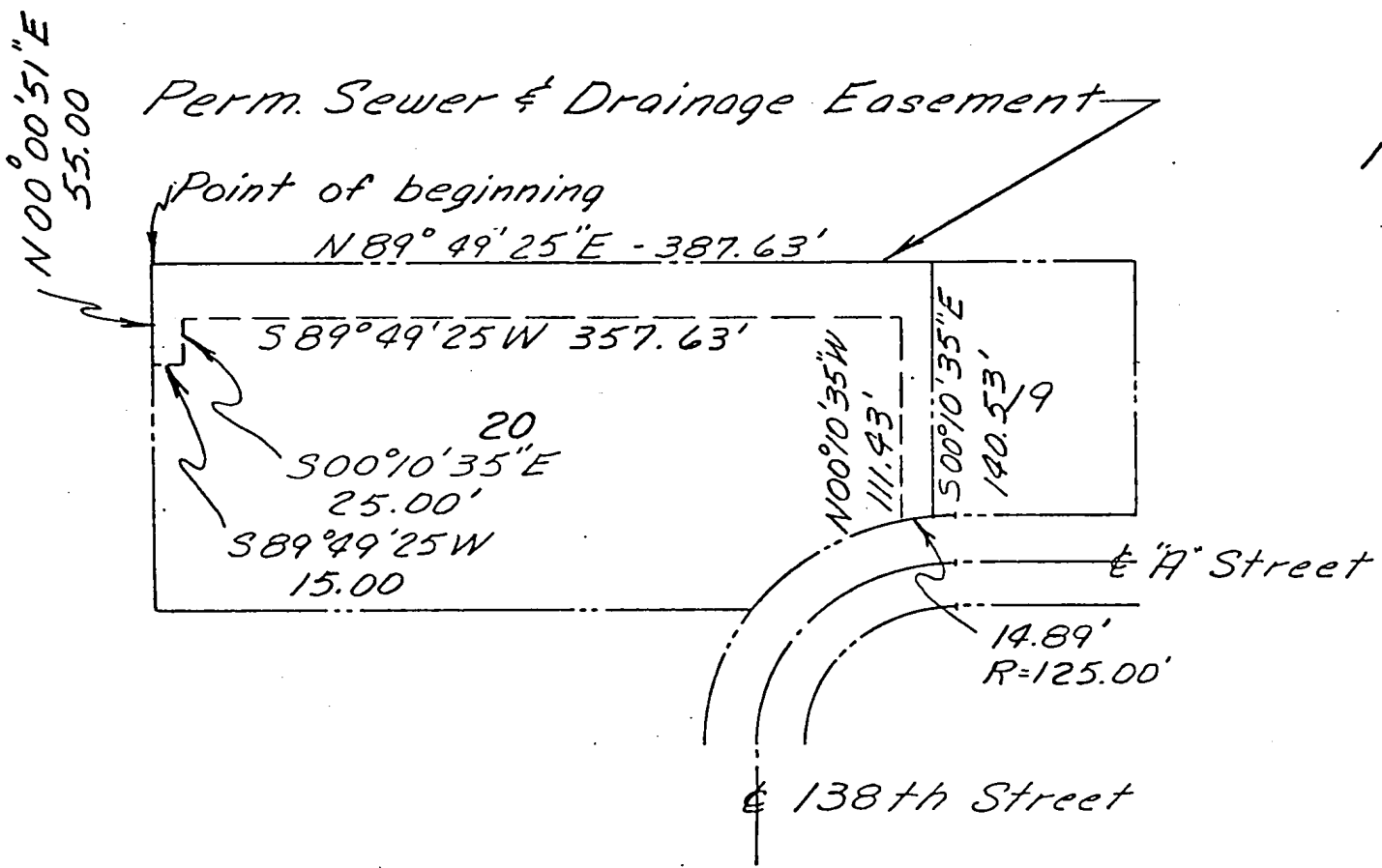

Legal Description: Lot 20, Southwest Park, a platted and recorded subdivision in Douglas County, Nebraska

Permanent Sewer and Drainage Easement.

Beginning at the Northwest corner of said Lot 20; thence North 89°49'25" East a distance of 387.63 feet; thence South 00°10'35" East a distance of 140.53 feet; thence Westerly along a 125.00 foot radius curve to the left an arc distance of 14.89 feet; thence North 00°10'35" West a distance of 111.43 feet; thence South 89°49'25" West a distance of 357.63 feet; thence South 00°10'35" East a distance of 25.00 feet; thence south 89°49'25" West a distance of 15.00 feet; thence north 00°00'51" East a distance of 55.00 feet to the point of beginning.

10' Perm. Sewer & Drainage Easement

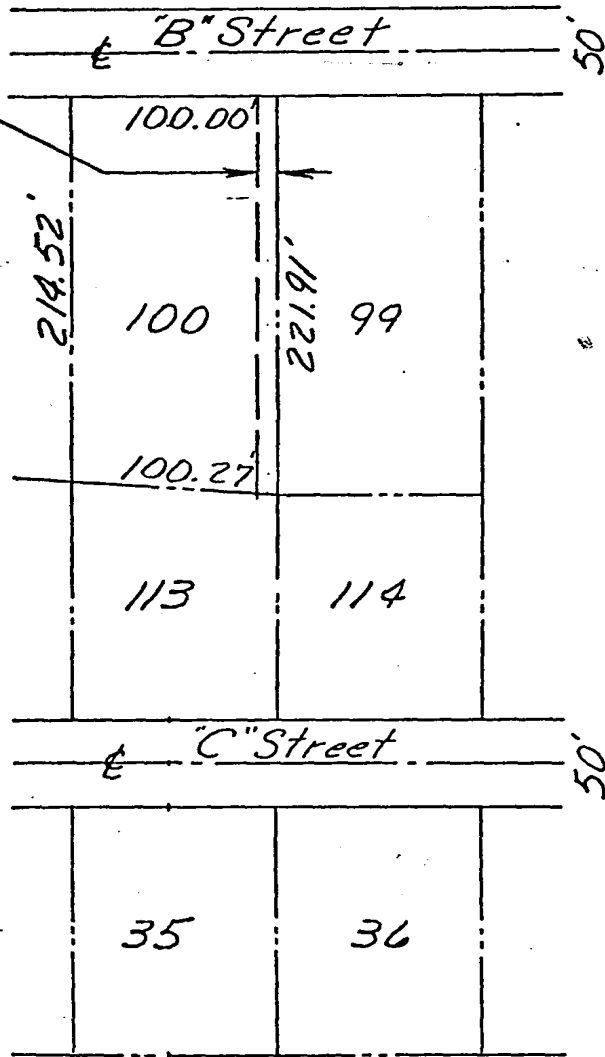

Legal Description: Lot 100, Southwest Park, a platted and recorded subdivision in Douglas County, Nebraska.

Permanent Sewer and Drainage Easement.

The East 10feet of said Lot 100.

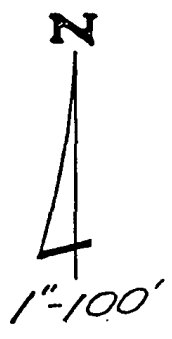
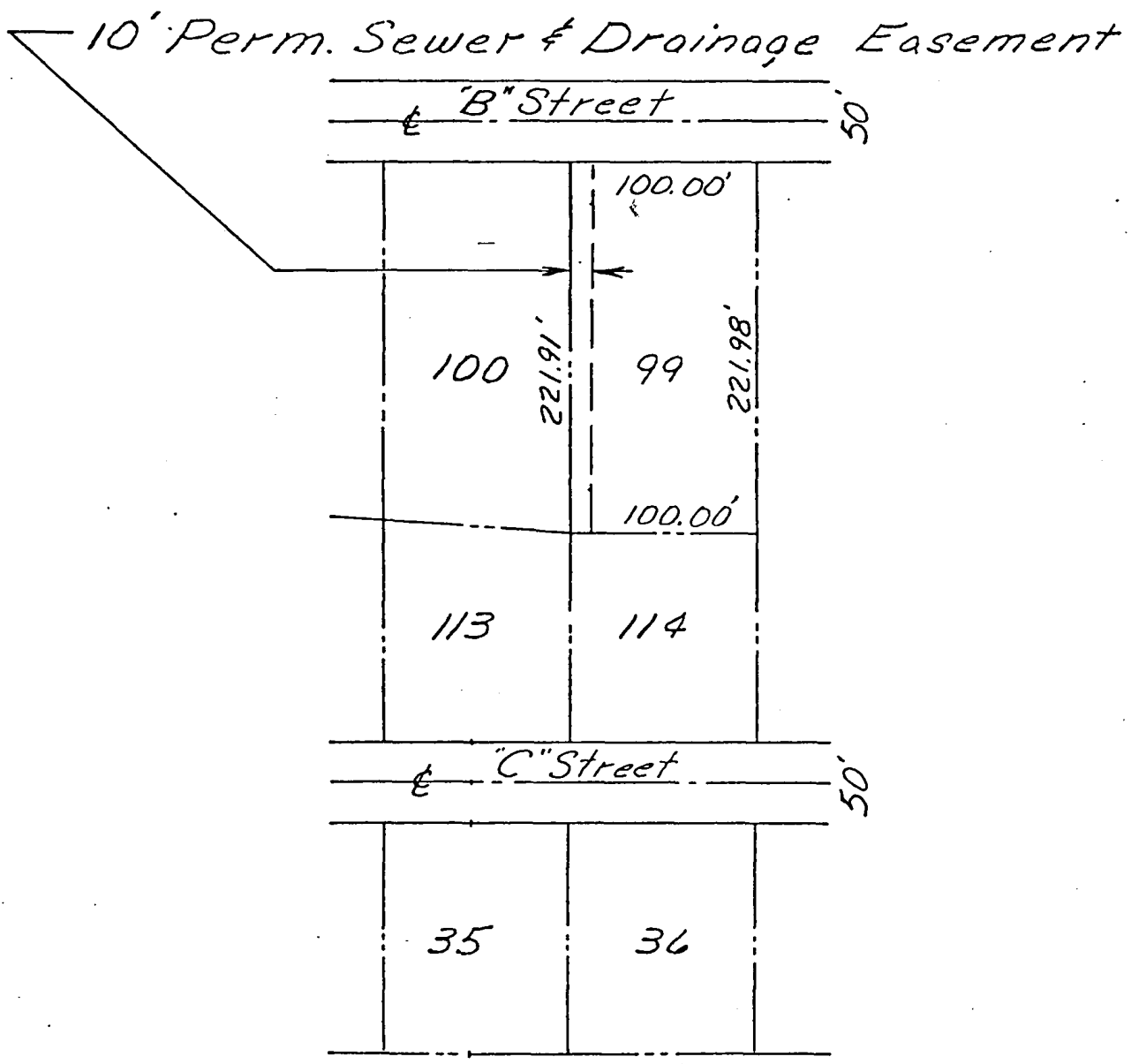

Legal Description: Lot 99, Southwest Park, a platted and recorded subdivision in Douglas County, Nebraska.

Permanent Sewer and Drainage Easement
 The West 10 feet of said Lot 99.

7

✓

15' Perm. Sewer & Drainage Easement

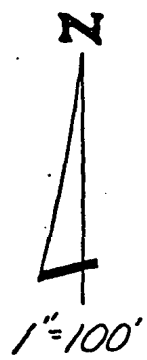
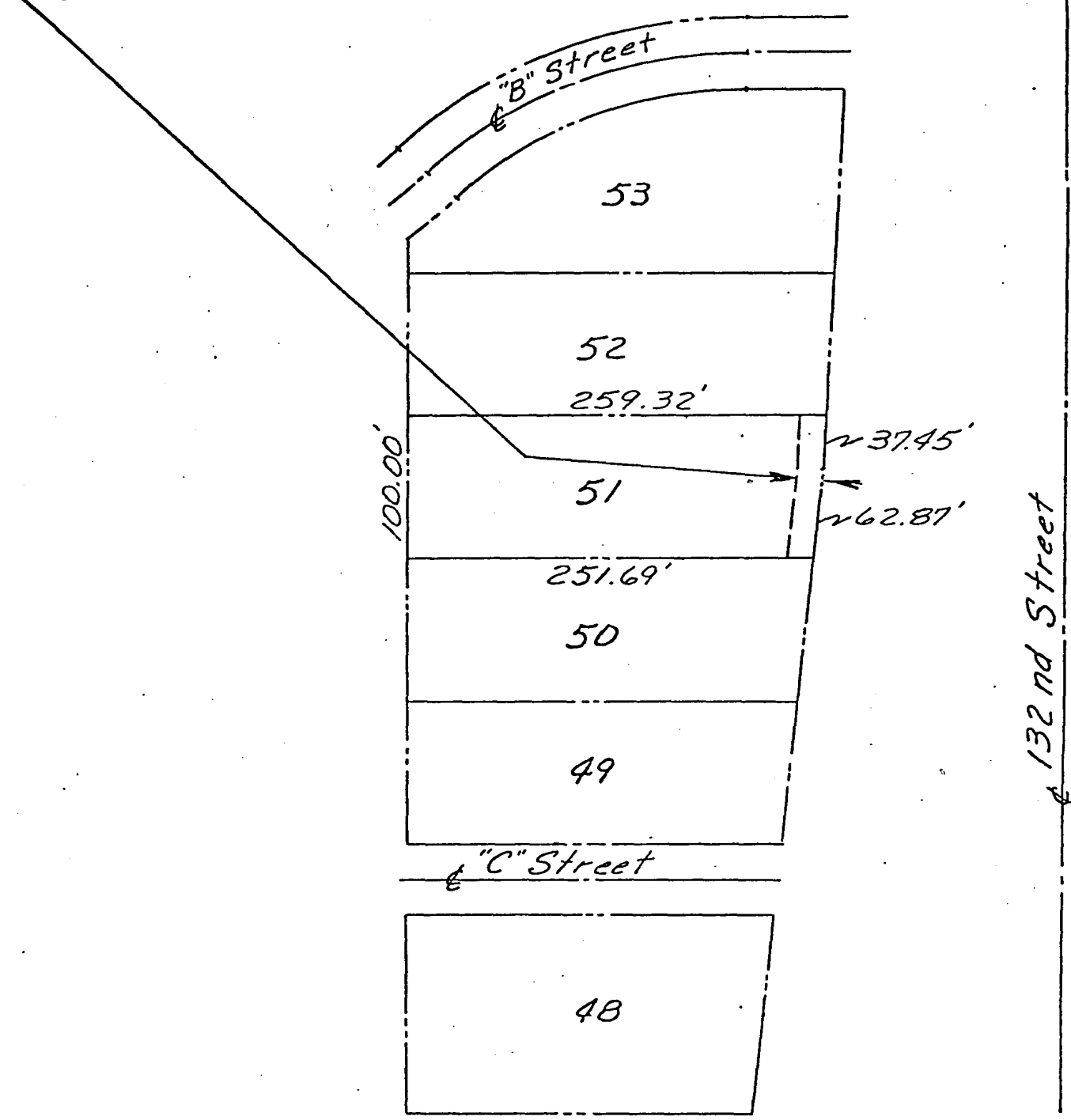

Legal Description - Lot 51, Southwest Park, a platted and recorded subdivision in Douglas County, Nebraska.

Permanent Sewer and Drainage Easement.

The East 15 feet of said Lot 51.

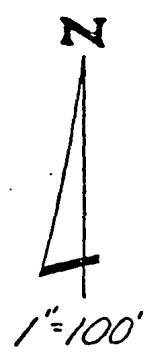
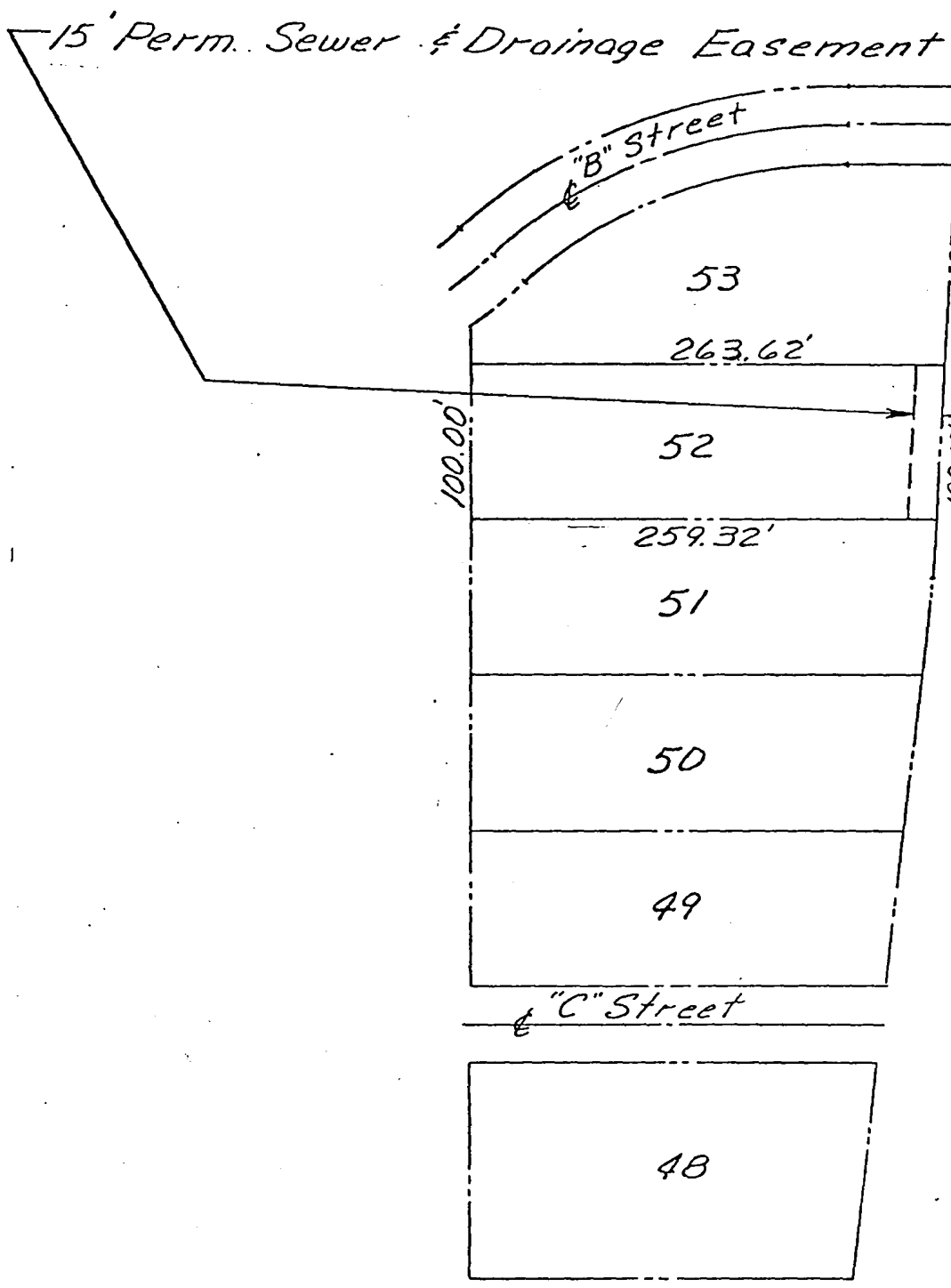

Legal Description: Lot 52, Southwest Park, a platted and recorded subdivision in Douglas County, Nebraska.

Permanent Sewer and Drainage Easement.

The East 15 feet of said Lot 52

<15' Perm. Sewer & Drainage Easement

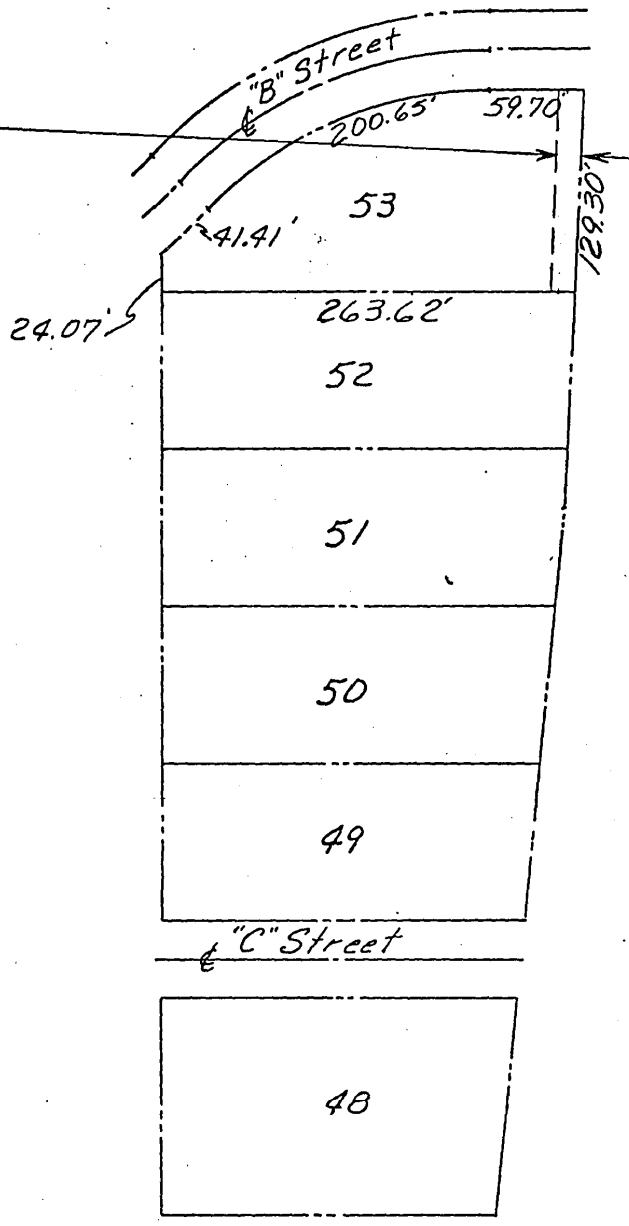

Legal Description - Lot 53, Southwest Park, a platted and recorded subdivision in Douglas County, Nebraska.

Permanent Sewer and Drainage Easement.

The East 15 feet of said Lot 53.

7 ENTERED IN NUMERICAL INDEX AND RECORDED IN THE REGISTER OF DEEDS OFFICE IN DOUGLAS COUNTY, NEBRASKA 67.25
 20 DAY OF Feb 1976 AT 3:27 P.M. C. HAROLD OSTLER, REGISTER OF DEEDS

✓