

99-25496

FILED SARPY CO. NE.

INSTRUMENT NUMBER
99-025496

CERTIFICATION

99 AUG 11 PM 4: 22

Glenn J. Lawling
REGISTER OF DEEDS

STATE OF NEBRASKA)
)
COUNTY OF SARPY) SS.
)
CITY OF LA VISTA)

I, Rita M. Ramirez, the duly appointed, qualified, and acting City Clerk of the City of La Vista, Sarpy County, Nebraska, hereby officially certify:

That the attached document is a true and correct copy of the subdivision agreement for Brook Valley Business Park between the City of La Vista, Brook Valley LTD Partnership, Prime Realty, Inc., and Sanitary and Improvement District No. 59 of Sarpy County dated February 23, 1993, as it appears in the official files of the City of La Vista.

IN WITNESS WHEREOF, I have hereunto set my hand and affixed the Seal of the City of La Vista hereto this 6th day of August, 1999.



Rita M. Ramirez
Rita M. Ramirez, CMC
City Clerk

Counter STEVE
Verify S
D.E. AK
Proof AK
Fee \$ 119.00
ek cash chg

99-25496 A

SUBDIVISION AGREEMENT
(Brook Valley Business Park)

THIS AGREEMENT, made this 23rd day of February, 1993, by and between BROOK VALLEY LTD PARTNERSHIP, a Nebraska Limited Partnership, Prime Realty, Inc., General Partner (hereinafter referred to as "Developer"), SANITARY AND IMPROVEMENT DISTRICT NO. 59 OF SARPY COUNTY, NEBRASKA (hereinafter referred to as "District"), and the CITY OF LA VISTA, a Municipal Corporation in the State of Nebraska (hereinafter referred to as "City");

W I T N E S S E T H:

WHEREAS, Developer is the legal and beneficial owner of the land included within the legal description attached hereto as "Exhibit "A" and the proposed plat attached hereto as Exhibit "B", which parcel of land, hereinafter referred as the "area to be developed," is outside the corporate limits of the City but within the City's zoning and platting jurisdiction; and

WHEREAS, Developer has requested City to approve a platting of the area to be developed, as more fully shown on Exhibit "B" hereto; and

WHEREAS, the area to be developed is situated within the boundaries of District, being that portion of the District situated west of 108th Street; and

WHEREAS, Developer has elected not to use the personal financing option for the construction of streets, storm sewers, sanitary sewers, and water and electric distribution systems within the area to be developed but instead wishes to finance same through District; and

WHEREAS, the parties wish to agree upon the manner and the extent to which public funds may be expended in connection with public improvements to be constructed within the area to be developed or serving the area to be developed and the extent to which the contemplated public improvements specially benefit property in the area to be developed and to what extent the cost of the same shall be specially assessed against the property of Developer;

NOW, THEREFORE, IT IS AGREED as follows:

1. Definitions

For the purposes of this Agreement, the following words and phrases shall have the following meanings:

- A. The "cost" or "entire cost" of a type of improvement shall be deemed to include all construction costs, engineering fees, attorneys' fees, testing expenses, publication costs, financing costs and miscellaneous costs. In this connection, financing costs shall include all fiscal agent's warrant fees and bond fees, interest on warrants to date of funding by issuance of bonds and bond fees. Miscellaneous costs of the improvement shall include the pro rata share of the general unallocated costs of the District, which unallocated costs shall be prorated to each improvement on the basis that the entire cost of each improvement bears to the entire cost of all improvements constructed by the District.
- B. "General obligation" or "general obligation of the District" shall mean the amount by which the entire cost of a particular improvement or type of improvement exceeds the amount of special assessments levied by the District in respect to such improvement or type of improvement.
- C. "Maximum general obligation" of the District shall mean the amount by which the total indebtedness of the District incurred in respect to all improvements within the area to be developed exceeds the

025496

total of special assessments levied in respect to all such improvements.

- D. "Property benefitted" shall mean property within the area to be developed (Exhibit "B") which constitutes buildable sites, as defined in Subparagraph 8-D, infra.
- E. "Street intersections" shall be construed to mean the area of the street between the returns of the various legs of the intersection, but in no case shall said area extend in any direction beyond a straight line drawn perpendicular from the centerline of the street to the adjacent lot corner, as shown in Exhibit "E" attached hereto.

2. Authorized Public Improvements

Developer, District and City agree that the credit of District shall be used for the construction of the following types of public improvements upon the property located within or adjacent to the boundaries of the District:

- A. Paving. Concrete paving of all streets dedicated per plat (Exhibit "B"), and illustrated on Exhibit "C" attached herewith, all said paving to be thirty (30) feet in width.
- B. Storm Sewer. Storm sewer system, including storm sewers, inlets, manholes, junction boxes, flared end sections and related appurtenances constructed in the dedicated street right-of-way per plat (Exhibit "B") or in dedicated easementways, as illustrated on Exhibit "C" hereto.
- C. Sanitary Sewer. All sanitary sewer mains, manholes and related appurtenances constructed in dedicated street right-of-way per plat (Exhibit "B") or in dedicated easementways, if any, as illustrated on Exhibit "C" hereto.
- D. Water. Water distribution mains, including the following: (1) the extension of the 16-inch diameter water main in 108th Street to the South line of the area to be developed; and (2) water distribution mains located within dedicated street right-of-way per plat (Exhibit "B") to be installed by Metropolitan Utilities District.
- E. Street Lighting. Street lighting for public streets dedicated per plat (Exhibit "B") to be installed by Omaha Public Power District.
- F. Electrical. Underground electrical service to each of the lots in the area to be developed to be installed by Omaha Public Power District.
- G. External Road Improvements. Auxiliary turn lanes in Harrison Street and the portions of intersections with Harrison Street and 108th Street as shown on Exhibit "D" hereto.

The exact design, location and dimensions of and detailed plans and specifications for each of the afore-described improvements are subject to prior approval by the City in advance of award of contract for construction. Except as herein expressly provided, the credit of the District shall not be used for the construction of any improvement.

3. Unauthorized Expenditures

Developer and District agree that the credit or funds of the District shall not be used for the planning, construction, acquisition or financing of any project, improvement, utility installation or connection, or for any facility except to the extent specifically authorized by Paragraph 2 hereof, supra. By way of specification and not by way of limitation, Developer and District agree

that District shall not incur any indebtedness or otherwise involve its credit or expend any of its funds in the planning, construction, acquisition, installation or financing of:

- A. Any swimming pool, golf course, park, playground, or other recreational facility.
- B. The advancement or payment of any fee, deposit, surcharge, demand charge or similar charge, whether or not refundable, imposed by any utility or other entity providing or contemplating providing utility-type service to the area to be developed.
- C. Any grading costs, except grading in street rights-of-way dedicated per plat (Exhibit "B"), the cost of which shall be one hundred percent (100%) specially assessed.
- D. Sidewalks.
- D. Any sodding, seeding or other landscaping, including that contemplated on street right-of-way, except for the replacement of existing grass in Harrison Street where necessary to construct auxiliary turn lanes.
- E. The payment of any sewer or water connection fee, sewer use or treatment fees, or water charge for lots or properties within or without the area to be developed.
- F. Any gas distribution system.
- G. The purchase of real estate or interest therein, except as may be authorized by the City.

4. Allocation of Cost of Improvements

Developer, District and City agree that the cost of all public improvements constructed by the District within the area to be developed (Exhibit "B"), as authorized by Paragraph 2, supra, shall be defrayed as follows:

- A. Paving. One hundred percent (100%) of the cost of all paving shall be paid by special assessment against the property benefitted within the area to be developed, except as follows: (1) the cost of that portion of each of the intersections which do not abut property, as more specifically shown on the typical intersection diagrams attached hereto as Exhibit "E" may be treated as a general obligation of the District; and (2) the cost of auxiliary turn lanes in Harrison Street and the portions of intersections with Harrison Street and 108th Street not abutting property all as shown on Exhibit "D" attached hereto.
- B. Storm Sewers. One hundred percent (100%) of the cost of all storm sewers, including manholes, inlets and other appurtenances, for storm sewers twenty-four (24") inches in size or less shall be specially assessed. Any storm sewer located in a public street or in an easement on private property whose size is required to be in excess of twenty-four (24") inches in size may be generally obligated for the difference in material and installation cost between a twenty-four (24") inch pipe and the actual size required, which difference may be generally obligated.
- C. Sanitary Sewers. One hundred percent (100%) of the cost of all sanitary sewers, including manholes and other appurtenances, shall be paid by special assessment against property benefitted within the

area to be developed. No portion of the cost of the sanitary sewer system shall be borne by general obligation of the District.

- D. Water. One hundred percent (100%) of the cost of the water distribution system serving the area to be developed shall be specially assessed against property benefitted within the area to be developed, including the entire cost of such contract charges as are authorized to be paid to Metropolitan Utilities District by the provision of Subparagraph 2-D, supra, except that fifty percent (50%) of the actual charges imposed by MUD for the extension of the sixteen (16") inch diameter water main referred to in Subparagraph 2-D hereof may be treated as a general obligation of the District. No portion of the cost of the water distribution system shall be borne by general obligation of the District, except as herein specifically provided.
- E. Street Lighting. The cost of the monthly contract charges paid to Omaha Public Power District for furnishing lighting of public streets, and maintenance and repair costs authorized under Paragraph 12, infra, shall be general obligation of the District.
- F. Electrical. One hundred percent (100%) of the cost of the underground electrical service serving the area to be developed, including contract charges authorized to be paid by District to Omaha Public Power District by the provisions of Subparagraph 2-F, supra, together with such other charges as fall within the definition of "entire cost" as defined in Subparagraph 1-A, supra, and are allocable to such contract charges, shall be specially assessed against property within the area to be developed. No portion of the cost of the underground electrical service system shall be borne by general obligation of the District.
- G. Sidewalks. The cost of sidewalks shall be paid by the Developer without use of District's credit or funds.

EXCEPT TO THE EXTENT SPECIFICALLY PROVIDED FOR IN THIS AGREEMENT TO THE CONTRARY, ANY AND ALL COSTS OR OBLIGATIONS WHICH THE DISTRICT SHALL INCUR IN CONNECTION WITH ANY IMPROVEMENT, FACILITY, CONSTRUCTION, UTILITY INSTALLATION OR FINANCING SHALL BE ONE HUNDRED PERCENT (100%) SPECIALLY ASSESSED. THE MAXIMUM GENERAL OBLIGATION DEBT HEREIN PROVIDED FOR SHALL NOT BE EXCEEDED.

5. Phasing of Construction

The Developer has requested and the City has acquiesced in Developer's request that the improvements described herein shall be constructed in two separate phases, Phase I, and Phase II. Special assessments shall be levied in the manner provided by law and in the amount required by this Agreement. Unless the City agrees otherwise, the Developer will levy all special assessments attributable to a particular improvement at one time and no lot shall be exempted from a levy solely by virtue of its location in either Phase I, or Phase II. Levies attributable to particular improvements shall in no way preclude subsequent levies for additional improvements.

6. Maximum General Obligation Debt

Developer and District warrant, covenant and agree that, notwithstanding any other provision of this Agreement to the contrary, the total amount of general obligation debt of the District arising from the District's activities and expenditures in connection with all phases of the construction of the improvements authorized herein shall not in the aggregate, in any event, exceed the total of the amount of general obligation authorized by subparagraphs 4-A, 4-B, 4-D and 4-E, supra. To the extent such general obligation of the District would have otherwise exceeded such total at date of levy of special assessments, the general obligation of the District shall be reduced and the amount specially

assessed for paving, storm sewer and sanitary sewer improvements shall be increased.

7. Formula to be Applied By on Both District and City

The method herein provided for computing special assessment and general obligation for the improvements herein authorized shall be binding on both the District and the City. City covenants and agrees that should City annex the area to be developed, or any part thereof, prior to District's levy of special assessments for the improvements authorized in Paragraph 2 hereof, supra, and thereby succeed to said District's power to levy special assessments, that City will levy same in accordance with Paragraphs 2 and 4 hereof, supra.

8. Covenants of Developer and District

Developer and District covenant and agree that the District created by Developer will:

- A. Abide by and incorporate into all construction contracts the provisions required by the regulations of the City pertaining to construction of public improvements in subdivisions and testing procedures therefor.
- B. Present to the City, prior to the commencement of construction of any improvement, binding contracts between the District and contractors providing for the installation of improvements authorized herein, and a binding agreement between the District and its fiscal agent providing for the placement of warrants and/or bonds of the District to finance the cost of the improvements authorized herein.
- C. Prior to commencement of construction of improvements, District will obtain and file of record permanent easements for all sanitary and storm sewer lines authorized by Paragraph 2 hereof, supra, which are not situated on dedicated street right-of-way. Said easements shall be granted by Developer at no cost to District or City and shall be in form satisfactory to City's Attorney and City's Engineer.
- D. Except as may otherwise be agreed to by City, all said District's levy of special assessments shall be made in such a manner so as to assure that the entire burden of the levy is borne, on a front foot or area basis, by lots or parcels or portions of lots or parcels which are truly buildable sites. If any lot, parcel, or part thereof, or other area within the area to be developed is not a buildable site by reason of insufficient size or dimensions or by reason of its having been acquired for any public purpose, or by reason of easements or similar burdens, or by reason of floodway or flood plain restrictions, or for any other reason, then no portion of the total amount to be levied for special assessments shall be levied against said unbuildable lot, parcel or other area, and the amount that otherwise would have been levied against same shall be spread and levied against the lots, or parts thereof, within the area to be developed which are buildable sites. The City's Engineer will determine which sites, if any, are not buildable sites. Attached hereto as Exhibit "F" is Developer's preliminary determination of the number of square feet of buildable area within each of the lots.
- E. At least thirty (30) days prior to setting the date of any hearing of District to be held for the purpose of equalizing or levying special assessments against property benefitted by any improvements constructed by District, submit to City:
 - 1) A detailed schedule of the proposed special assessments;

- 2) A plat of the area to be assessed;
- 3) A full and detailed statement of the entire cost of each type of improvement, which statement or statements shall separately show:
 - a. the amount paid to contractor;
 - b. a special itemization of all other costs of the project, including, but not limited to, all engineering fees, attorneys' fees, testing expenses, publication costs, financing costs, including, but not limited to, interest on all warrants to date of funding by issuance of bonds, estimated fiscal agent's warrant fees and bond fees;
 - c. a special itemization of all unallocated and unpaid costs of the District as defined in Subparagraph 1-A, supra.
- F. In setting the rate of interest for special assessments levied by the District, the District shall set same at the maximum authorized by law for special assessments.
- G. District shall not proceed with any levy of special assessments except in accordance with the terms hereof and only after City has determined the proposed special assessments to be in accordance herewith.
- H. In the performance of this contract, the District shall not discriminate against any parties on account of race, national origin, sex, age, political or religious affiliations in violation of Federal or State laws or local ordinances.
- I. Should any of the platted lots per Exhibit "B" be split, all special assessments levied on the lot will be paid at the time of such lot split, unless the City otherwise agrees.

9. Partial Annexation

The parties mutually agree that in the event City shall annex any part of the area shown on Exhibit "B" hereto and said annexation shall not include the then entire territory of the District, then a division of assets and liabilities of the District in connection with such partial annexation of the District shall be made as may be agreed by City and District, and if they are unable to agree, then in the manner provided in Section 31-766 of the Nebraska Revised Statutes, 1943, Reissue 1988, as amended and in effect at the time. The City shall be under no obligation to annex the area to be developed or any part thereof.

10. Construction Standards and Procedures

District and Developer further agree that, as to all improvements constructed by or on behalf of the District or under its control or direction, that:

- A. All such improvements will be constructed in strict accordance with plans and specifications and locations approved in writing by City's Engineer and in strict accordance with the minimum standards and requirements of construction adopted by the City and in effect at the time of construction of said improvements, and that upon completion of construction thereof, District shall furnish to City a certificate from its Consulting Engineers so certifying.
- B. District shall cause "as Built Plans," in reproducible form, and specifications for all such improvements that District shall have

heretofore or hereafter constructed within the area to be developed to be furnished to City, in triplicate, promptly and without cost to the City. All such plans shall be submitted on reproducible linens, except where the City agrees otherwise. The engineering costs attributable to the production of said "As Built Plans" shall be an engineering cost within the meaning of Subparagraph 1-A, supra. District shall, prior to the District's advertising for bids for any improvement within the area to be developed, require District's Engineers to file with city said Engineers' separate written assurance and agreement that said "As Built Plans" will be prepared and filed with the City upon the completion of each improvement.

- C. All such improvements shall comply with all applicable federal and state laws and regulations in general and with all applicable ordinances and regulations of the City in reference to construction, use, operation and maintenance.
- D. In the event that City's Engineers determine that there is anything in the construction, maintenance or operation of any such improvements which will, in the opinion of City's Engineers, be detrimental to any other improvement or utility constructed or to be constructed in the same street right-of-way or easementway, District will, on notice thereof, promptly cause its engineers to jointly review and evaluate the problem with City's engineer and formulate a plan for corrective action which shall be implemented by District at District's cost.
- E. District shall require each contractor to furnish a performance and maintenance bond, with District and City as joint and several obligees thereon, which bond shall be satisfactory to the City as to surety, form and terms.

11. Administrative Fee

Developer and District agree that, in addition to whatever inspection and testing that District shall perform or cause to be performed, City reserves the right to cause City's own inspection to be made of all construction of public improvements constructed by District, whether within or without the area to be developed. District agrees that it will pay to City an amount equal to two percent of the construction cost of all improvements constructed by or for the District, including electrical and water distribution systems constructed pursuant to contracts between the District and Omaha Public Power District or Metropolitan Utilities District, as well as all other improvements authorized under Paragraph 2, supra, as reimbursement to City for engineering, legal and administrative expenses incurred by City in connection with administration of this Agreement. Said administration fee shall be paid to City as follows:

- A. The first installment shall constitute one percent of the construction cost estimate for the various improvements computed by the engineer and shall be paid to the City at the time the City approves the plans and specifications of the improvements; and
- B. The remaining portion of said fee, if any, shall be paid at the time of the acceptance of the improvements by the District, and shall be equal to two percent (2%) of the final construction contract amounts reduced by the first installment paid pursuant to Subparagraph A above.

Said fees shall be a cost of the improvements within the meaning of Subparagraph 1-A, supra, and shall be prorated among improvements in the same ratio that the entire cost of each improvement bears to the entire cost of all improvements constructed by the District.

12. Testing Expense

District shall cause appropriate testing of materials and work finished in respect to the construction of improvements and shall furnish City's engineers with copies of test results. City's engineers may order additional paving core tests, sewer televising or other tests, the cost of which, not to exceed Ten Thousand Dollars (\$10,000.00), shall be paid by District to the party performing the testing procedures;--which additional testing costs, not to exceed Ten Thousand Dollars (\$10,000.00), shall also be a cost of the improvement. Neither the Developer nor the District nor any other party shall be entitled to rely upon any inspections made by the City for any purpose whatsoever. The sole responsibility for proper inspection and certification as to completion remains with the District and its engineers.

13. Maintenance of Improvements

It is further agreed that the District shall maintain and keep in good repair all improvements authorized to be constructed within the boundaries of the District pursuant to Paragraph 2, supra. Prior to expending District credit or funds on any major repairs, District shall first make a determination that the project would not be covered by the performance bond and/or any separate maintenance bond executed by the contractor involved in the original construction of said improvement. Repairs reasonably estimated to cost more than Twenty-five Thousand Dollars (\$25,000.00) shall be subject to prior approval of City.

14. Miscellaneous

It is further mutually agreed:

- A. District need not construct the extension of the water main in 108th Street to the South end of the area to be developed until such time as City or Metropolitan Utilities District determines that such extension should be constructed.
- B. That the District shall levy an annual mill levy sufficient to fully comply with applicable statutes and, in all events not less than that necessary to produce an amount of taxes sufficient to pay all general operating expenses of the District, including street lighting, water hydrant fees, and maintenance, repair and reconstruction costs authorized and required under Paragraph 13, supra, together with interest on that portion of the District's indebtedness that exceeds the total amount of outstanding special assessments of the District; and
- C. That in addition to whatever rights of enforcement of the terms hereof are herein granted to any party, each party may avail itself of all other remedies it may have to enforce the terms hereof at law or equity. By way of specification and not by way of limitation, each of the parties expressly reserve to and right to specifically enforce full compliance of the terms and conditions of this agreement by mandatory or prohibitory injunction.
- D. The covenants hereof of Developer and the District are joint and several and shall constitute covenants running with the land.
- E. The parties mutually agree that at this time public sidewalks are not necessary, but City reserves the right to require sidewalks in the future as City may determine necessary along 108th Street and along Harrison Street, which, if required, shall be at the cost of the Developer or its successor in interest.

15. Exhibit Summary

The Exhibits attached hereto and made a part hereof are as follows:

- Exhibit "A": Metes and bounds legal description of the area to be developed.
- Exhibit "B": Plat of area to be developed.
- Exhibit "C": Plat drawing showing type and location of public improvements.
- Exhibit "D": Illustration of auxiliary turning lanes in Harrison Street and street intersections with Harrison Street and with 108th Street outside the boundaries of District which are to be constructed by District, consisting of 4 pages.
- Exhibit "E": Illustration of typical internal street intersections, showing portions thereof to be general obligation and portions to be specially assessed.
- Exhibit "F": Page F-1 - Developer's preliminary drawing of areas excluded from special assessment by reason of being non-buildable.
Page F-2 - Developer's preliminary determination of number of square feet of buildable land within each of the platted lots.

IN WITNESS WHEREOF, we, the parties hereto, by our respective duly authorized agents, hereto affix our signatures and seals at La Vista, Nebraska, the day and year first above written.

ATTEST: BROOK VALLEY LTD. PARTNERSHIP, a Nebraska Limited Partnership
PRIME REALTY, INC., GENERAL PARTNER

Betty J. McCart Secretary By: James V. McCart
Its President

ATTEST: SANITARY AND IMPROVEMENT DISTRICT
NO. 59 OF SARPY COUNTY, NEBRASKA

Paul Kiedemeyer Clerk of Said District By: John Munzweather
Chairman of the Board of Trustees

ATTEST: CITY OF LA VISTA

Dorothy A. McGinnis City Clerk By: Harold Anderson
Harold Anderson, Mayor

STATE OF NEBRASKA)
COUNTY OF Douglas) ss.

On this 23rd day of February, 1993, before me, the undersigned, a notary public in and for said county, personally came James V. McCart, to me personally known to be the President of Prime Realty, Inc., General Partner of

Brook Valley Ltd. Partnership, and Betty McLart, to me personally known to be the Secretary of Prime Realty, Inc, the identical persons whose names are affixed to the foregoing Subdivision Agreement, and they acknowledged the execution thereof to be their voluntary act and deed.

WITNESS my hand and notarial seal the day and year last above written.

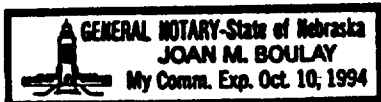

Joan M. Boulay
Notary Public

STATE OF NEBRASKA)
COUNTY OF Douglas) ss.

On this 23rd day of February, 1993, before me, the undersigned, a notary public in and for said county, personally came John Henryweather, to me personally known to be the Chairman of the Board of Trustees of Sanitary and Improvement District No. 59 of Sarpy County, Nebraska, and Wm J. Wiedmeyer to me personally known to be the Clerk of the Board of Trustees of Sanitary and Improvement District No. 59 of Sarpy County, Nebraska, the identical persons whose names are affixed to the foregoing Subdivision Agreement, and they acknowledged the execution thereof to be their voluntary act and deed.

WITNESS my hand and notarial seal the day and year last above written.

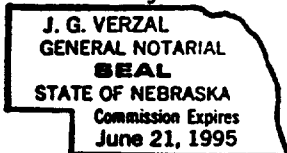

J. G. Verzal
Notary Public

STATE OF NEBRASKA)
COUNTY OF Sarpy) ss.

On this 2nd day of March, 1993, before me, the undersigned, a notary public in and for said county, personally came HAROLD ANDERSON, to me personally known to be the Mayor of the City of La Vista, and DOROTHY A. MCGINNIS, to me personally known to be the Clerk/Treasurer of the City of La Vista, the identical persons whose names are affixed to the foregoing Subdivision Agreement, and they acknowledged the execution thereof to be their voluntary act and deed.

WITNESS my hand and notarial seal the day and year last above written.



Rita M. Aiken
Notary Public

99-25496 K

SURVEYOR'S CERTIFICATE

I HEREBY CERTIFY THAT I HAVE MADE A BOUNDARY SURVEY OF THE SUBDIVISION HEREIN AND THAT IRON PIPES OR PERMANENT MARKERS HAVE BEEN SET AT ALL CORNERS OF SAID BOUNDARY AND THAT A BOND WILL BE POSTED WITH THE CITY OF LA VISTA TO INSURE THAT IRON PIPES WILL BE SET AT ALL LOT CORNERS, ANGLE POINTS AND AT THE ENDS OF ALL CURVES WITHIN SAID SUBDIVISION TO BE KNOWN AS BROOK VALLEY BUSINESS PARK, LOTS 1 THRU 28, INCLUSIVE, BEING A PLATTING OF THAT PART OF THE EAST 1/2 OF SECTION 17, T14N, R12E OF THE 6TH P.M. SARPY COUNTY, NEBRASKA, DESCRIBED AS FOLLOWS: COMMENCING AT THE NE CORNER OF SAID SECTION 17, THENCE S02°37'19"E (ASSUMED BEARING) 50.00 FEET ON THE EAST LINE OF SAID SECTION 17; THENCE S87°38'24"W 60.00 FEET ON A LINE 50.00 FEET SOUTH OF AND PARALLEL TO THE NORTH LINE OF SAID SECTION 17 TO THE POINT OF BEGINNING, SAID POINT BEING ON THE SOUTH LINE OF HARRISON STREET. THENCE WESTERLY ON THE SOUTH LINE OF HARRISON STREET ON THE FOLLOWING DESCRIBED SEVEN COURSES, THENCE S87°38'24"W 1507.76 FEET, THENCE S69°22'38"W 86.16 FEET, THENCE N73°34'53"W 83.87 FEET; THENCE S87°38'24"W 120.64 FEET, THENCE S80°14'00"W 100.84 FEET; THENCE S83°03'30"W 287.92 FEET; THENCE S85°36'39"W 78.93 FEET, THENCE S00°08'15"W 940.10 FEET; THENCE S21°21'40"E 1052.34 FEET, THENCE S12°04'42"E 689.92 FEET TO THE NORTH LINE OF THE C.B. & Q. RAILROAD; THENCE EASTERLY ON THE NORTHERLY LINE OF THE C.B. & Q. RAILROAD ON THE FOLLOWING SEVEN DESCRIBED COURSES, THENCE NORTHEASTERLY ON A 2914.79 FOOT RADIUS CURVE TO THE RIGHT, CHORD BEARING N87°59'27"E, CHORD DISTANCE 822.04 FEET, AN ARC DISTANCE OF 824.79 FEET TO A POINT OF COMPOUND CURVE; THENCE SOUTHEASTERLY ON A 2930.39 FOOT RADIUS CURVE TO THE RIGHT, CHORD BEARING S79°44'57"E, CHORD DISTANCE 424.49 FEET, AN ARC DISTANCE OF 424.86 FEET, THENCE N62°46'47"W 301.24 FEET TO THE SOUTH LINE OF THE NORTH 1/2 OF SAID SECTION 17; THENCE N87°33'56"E 303.37 FEET ON THE SOUTH LINE OF THE NORTH 1/2 OF SAID SECTION 17; THENCE S62°46'47"E 151.00 FEET TO A POINT OF CURVE, THENCE SOUTHEASTERLY ON A 3921.68 FOOT RADIUS CURVE TO THE RIGHT, CHORD BEARING S60°56'39"E, CHORD DISTANCE 251.23 FEET, AN ARC DISTANCE OF 251.27 FEET TO A POINT OF TANGENCY, THENCE S59°06'31"E 273.19 FEET TO THE WEST LINE OF 108TH STREET, THENCE NORTHERLY ON THE WESTERLY LINE OF 108TH STREET THE FOLLOWING FIVE DESCRIBED COURSES: THENCE NORTHEASTERLY ON A 638.75 FOOT RADIUS CURVE TO THE LEFT, CHORD BEARING N20°18'25"W, CHORD DISTANCE 178.52 FEET, AN ARC DISTANCE OF 179.10 FEET TO A POINT OF REVERSE CURVE; THENCE NORTHWESTERLY ON A 588.00 FOOT RADIUS CURVE TO THE RIGHT, CHORD BEARING N05°32'16"W, CHORD DISTANCE 455.75 FEET, AN ARC DISTANCE OF 468.01 FEET TO A POINT OF REVERSE CURVE; THENCE NORTHEASTERLY ON A 1450.00 FOOT RADIUS CURVE TO THE LEFT, CHORD BEARING N07°19'16"E, CHORD DISTANCE 500.74 FEET, AN ARC DISTANCE OF 503.26 FEET TO A POINT OF TANGENCY, THENCE N02°37'19"W 1828.45 FEET ON A LINE 50.00 FEET WEST OF AND PARALLEL TO THE EAST LINE OF SAID SECTION 17, THENCE N47°29'46"W 14.17 FEET TO THE POINT OF BEGINNING



NOVEMBER 10, 1992
DATE

JAMES D. WARNER, R.L.S. 308

EXHIBIT "A"
PAGE A-1

99-25491

BROOK VALLEY BUSINESS PARK

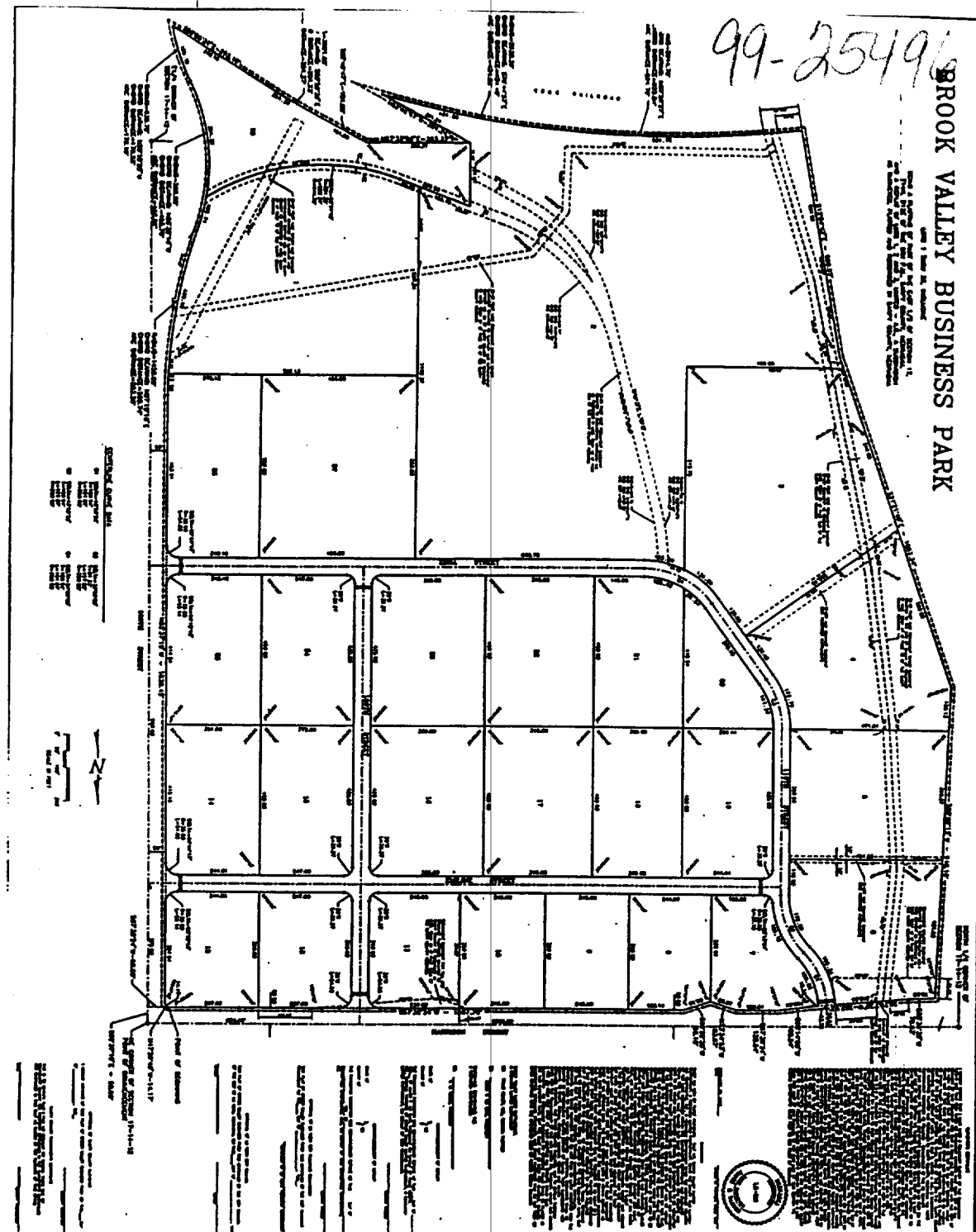

2

THOMPSON, DREESSEN & DORNER
Consulting Engineers & Land Surveyors
2020 2nd St., Suite 100
Casper, WY 82401
(307) 234-1000

BROOK VALLEY BUSINESS PARK

FINAL PLAN

DATE	AS SHOWN
NO.	13-10-02
BY	SDP
CHK	SDP

EXHIBIT "B"
PAGE B-1

99-25496 M

BROOK VALLEY BUSINESS PARK

(PLANNED COMMUNITY DEVELOPMENT)
RESIDENTIAL ZONE R



- EXISTING BUILDINGS
- EXISTING DRIVEWAYS
- EXISTING DRIVEWAYS
- EXISTING DRIVEWAYS
- EXISTING DRIVEWAYS

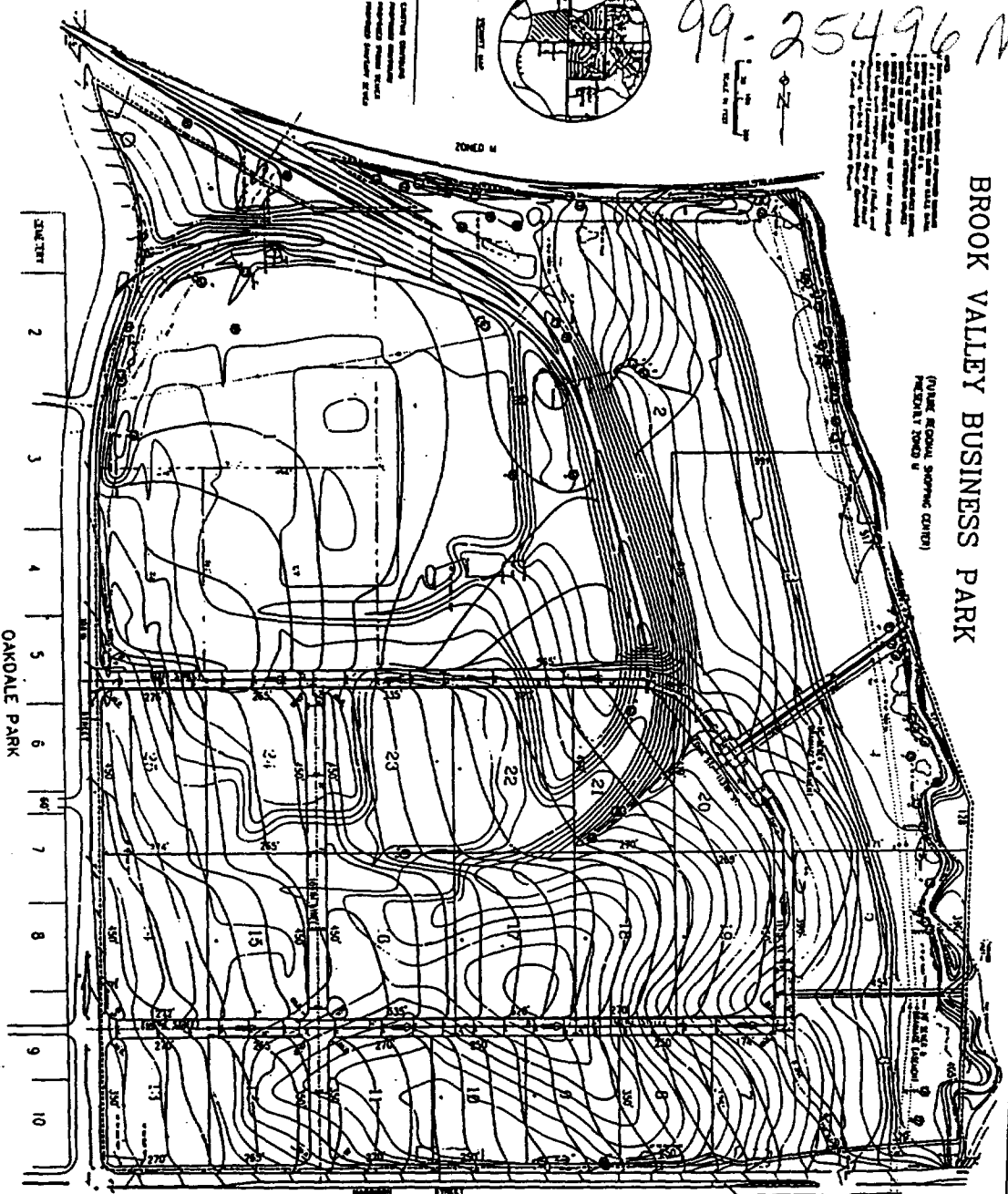

JUNIPER 2 3 4 5 6 7 8 9 10

OAKDALE PARK

482

BROOKHAVEN

481

480

PROPOSED LOT LAYOUT
AND DRIVEWAY LAYOUT
SHOWN FOR INFORMATION ONLY
NOT TO BE USED FOR CONSTRUCTION

PROPOSED LOT LAYOUT
AND DRIVEWAY LAYOUT
SHOWN FOR INFORMATION ONLY
NOT TO BE USED FOR CONSTRUCTION



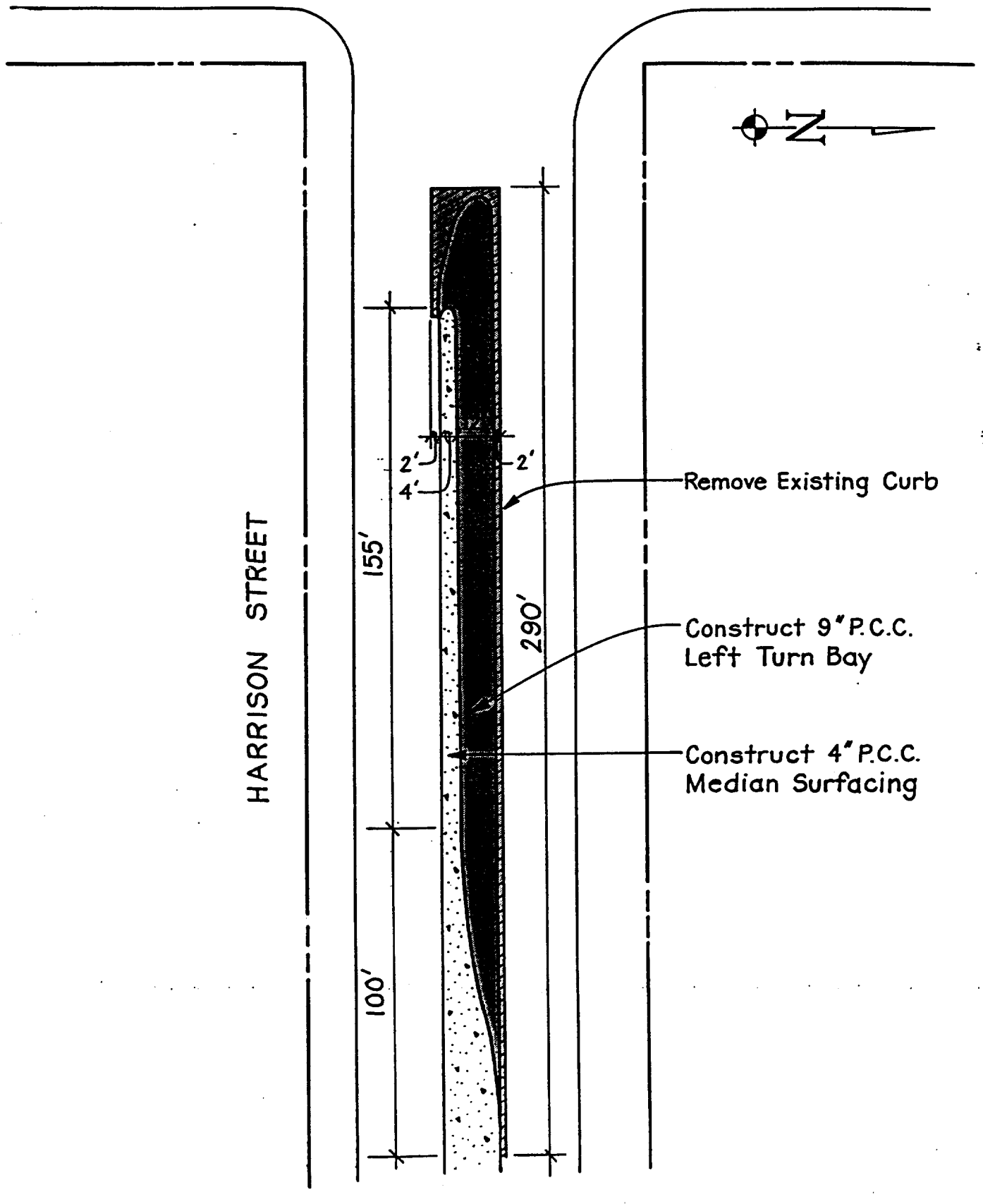

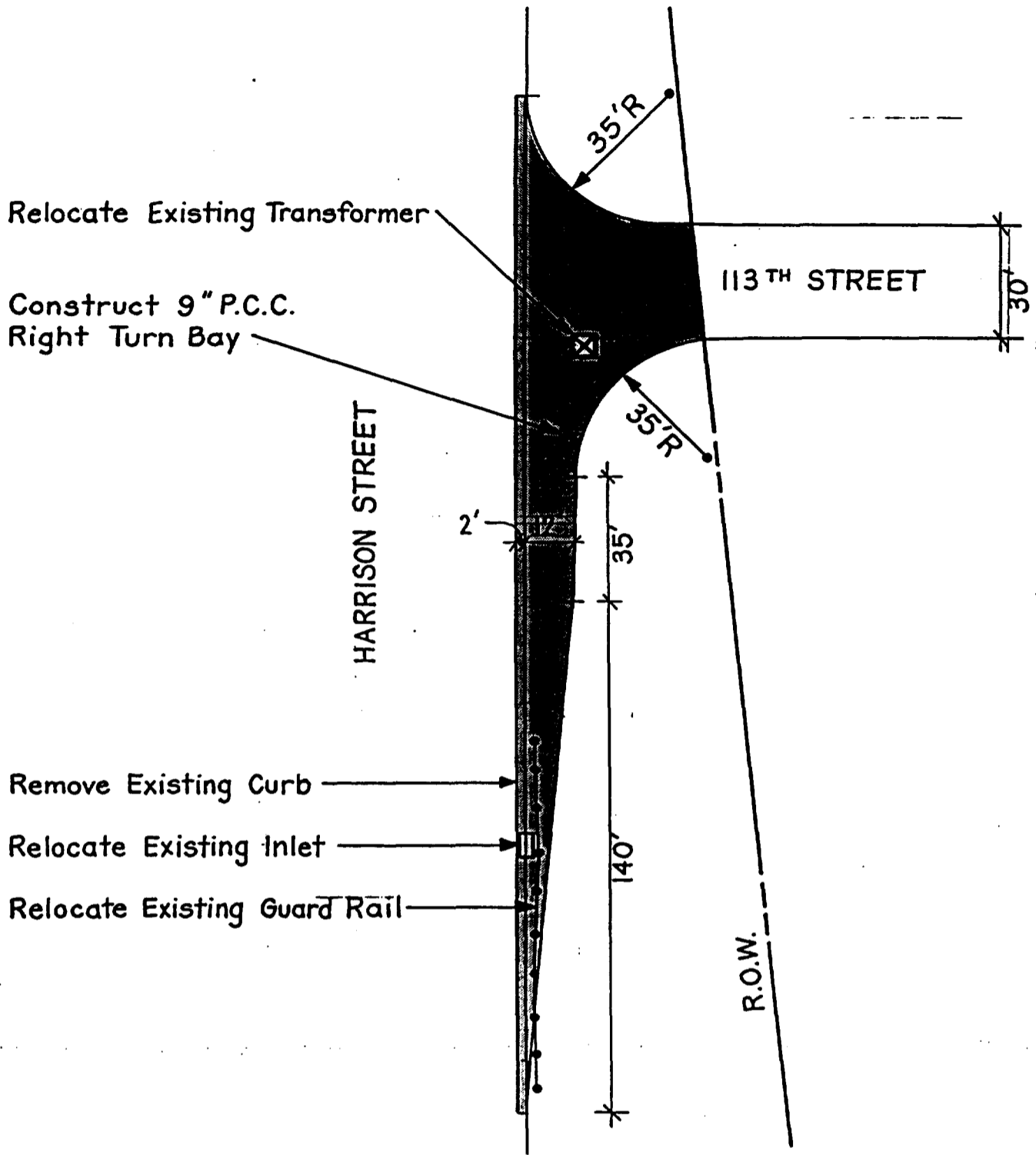
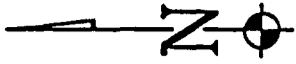

NOTE :

Work Shown On This Sheet May Be A General Obligation Expense.

99-25496 P
70

Remove Existing Curb

109TH STREET

HARRISON STREET

Construct 9" P.C.C.
Right Turn Bay

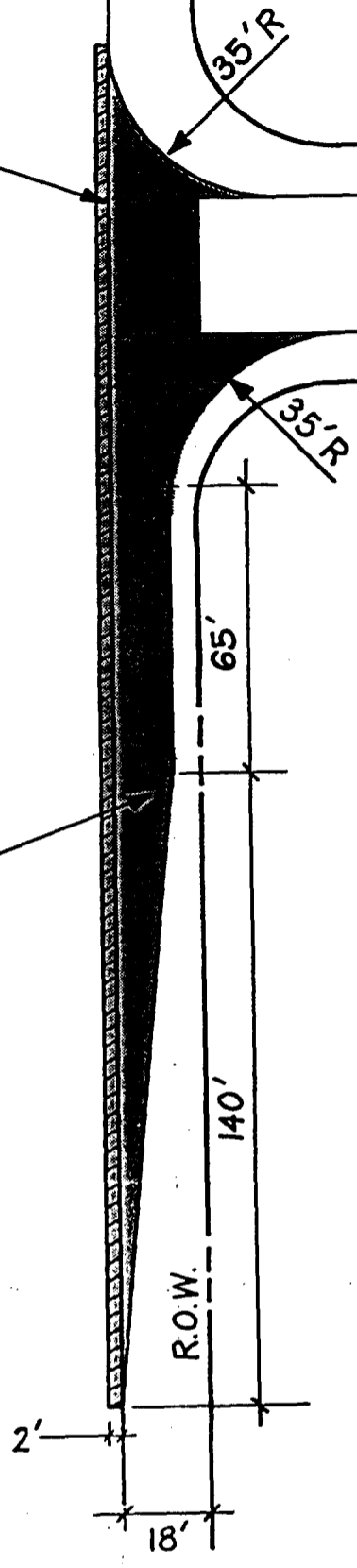
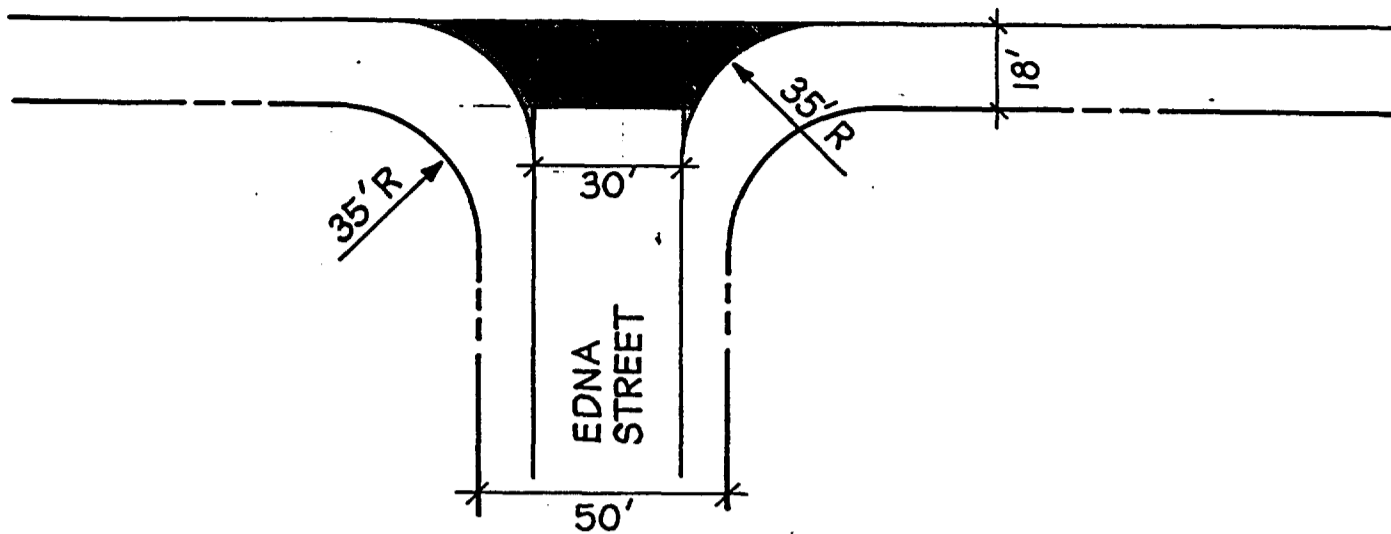

EXHIBIT "D"
PAGE D-3

99-25496 Q

108TH STREET



108TH STREET

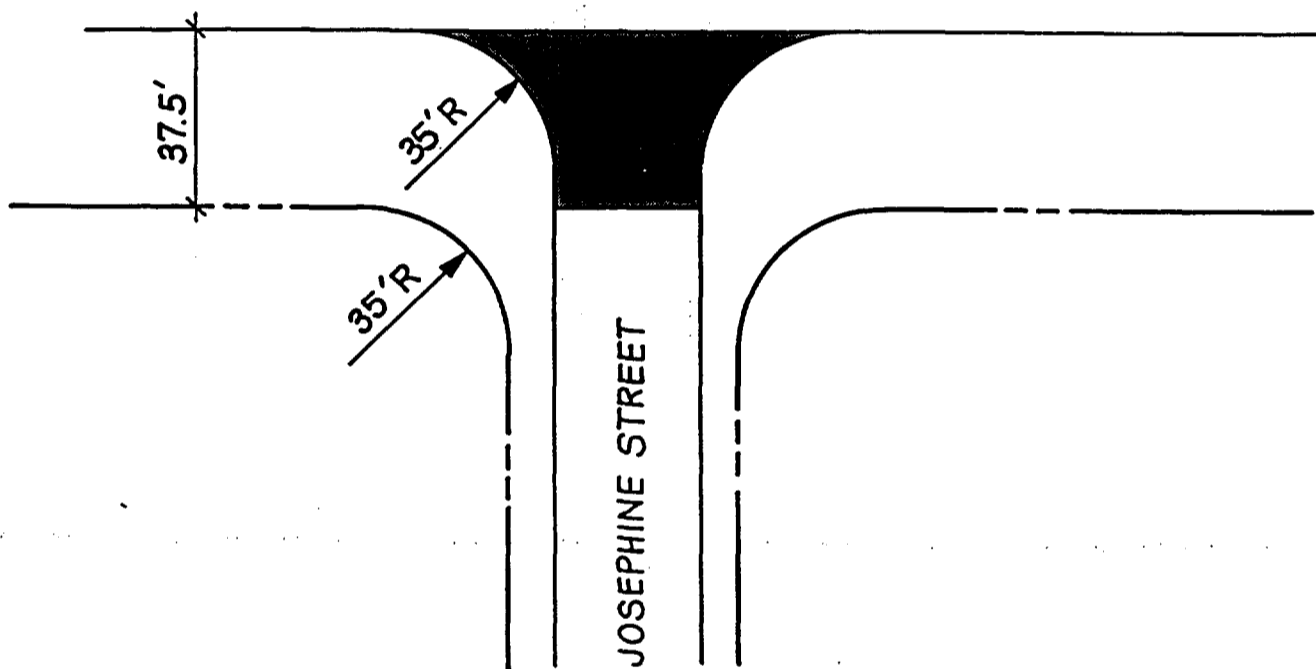
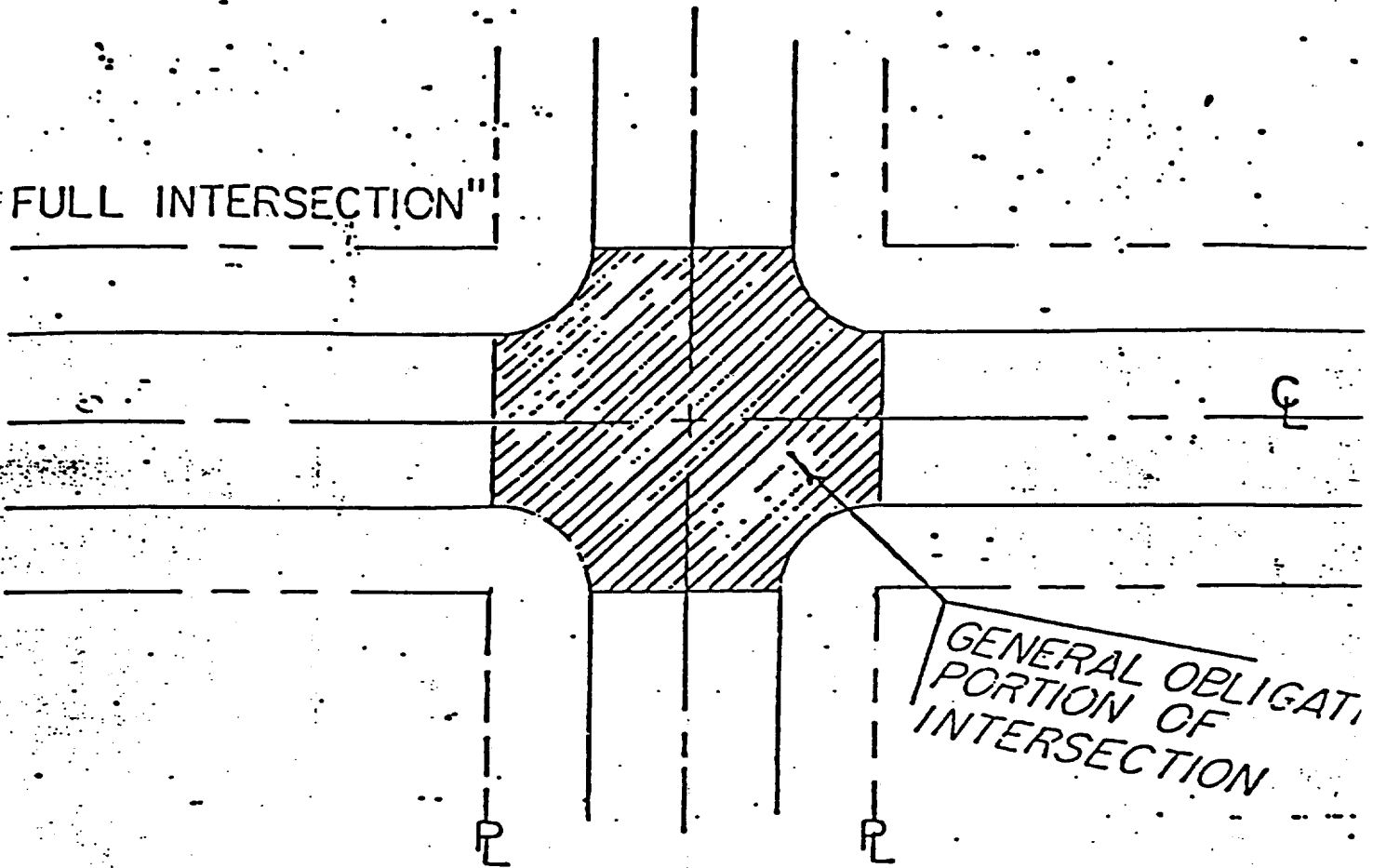

EXHIBIT "D"
PAGE D-4

"FULL INTERSECTION"



GENERAL OBLIGATION PORTION OF INTERSECTION

"T INTERSECTION"

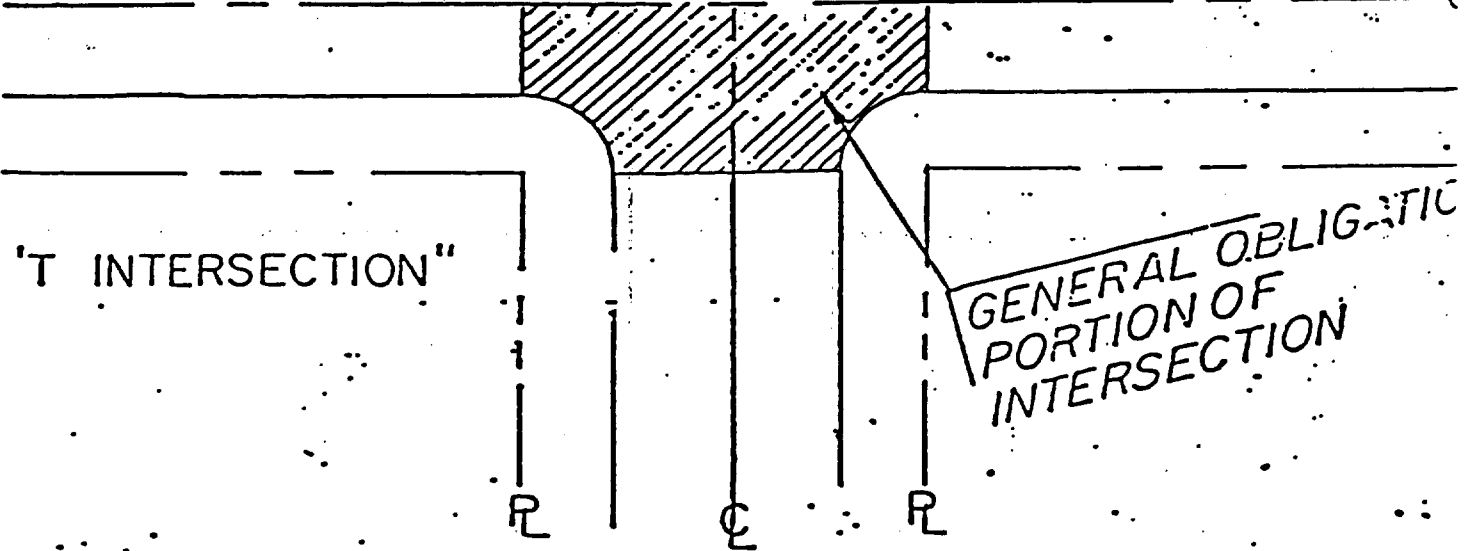

GENERAL OBLIGATION PORTION OF INTERSECTION

99-25496

BROOK VALLEY BUSINESS PARK

Map 1 of 1
Scale: 1" = 100'

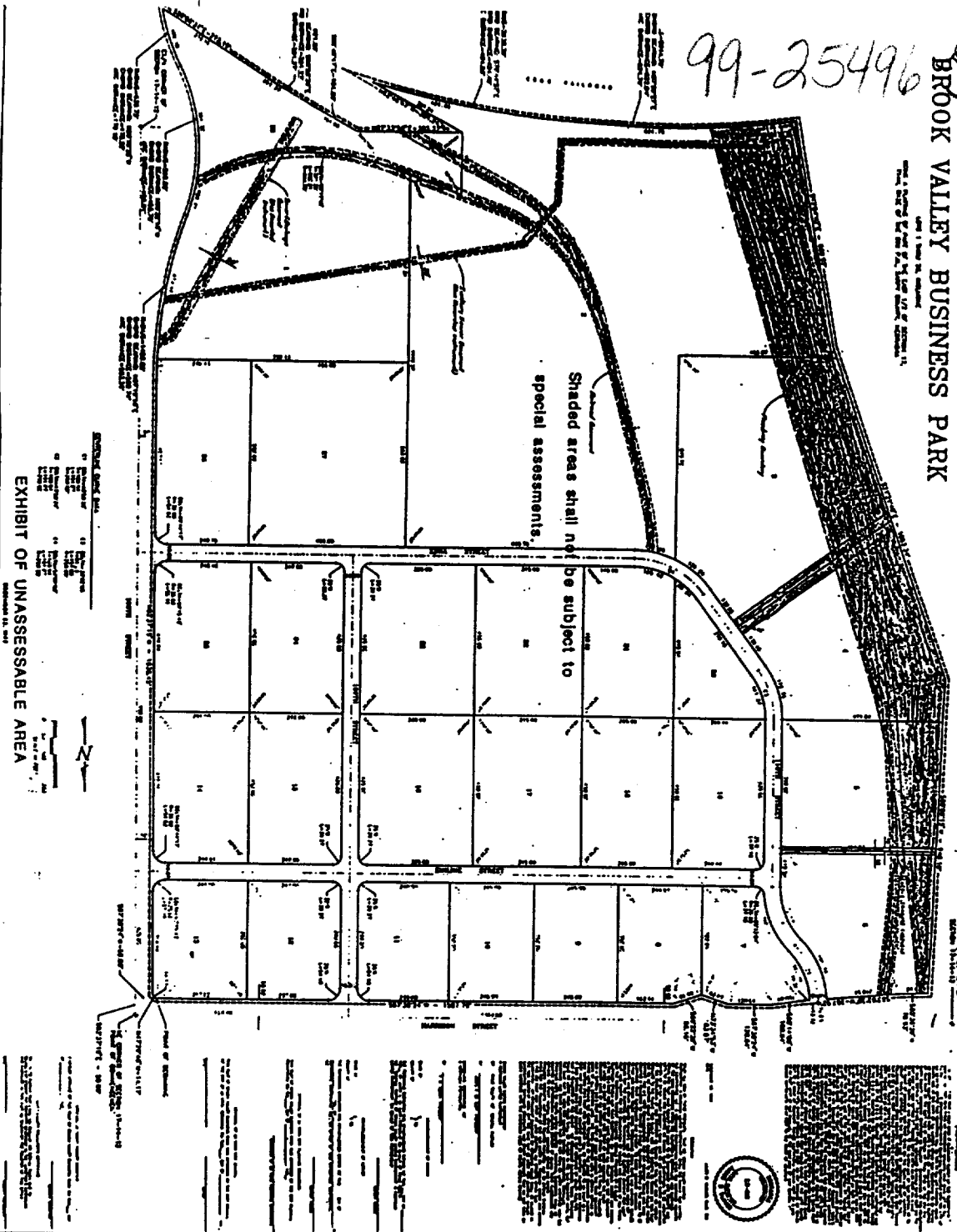

	2 THOMPSON, DREESSEN & DORNIER Consulting Engineers & Land Surveyors 1000 10th Ave. SW Grand Rapids, MI 49503 (616) 451-1000	BROOK VALLEY BUSINESS PARK		Date: 12-10-03 Scale: 1" = 100' Drawn by: JWP
		FINAL PLAN		

99-25496 T

BROOK VALLEY BUSINESS PARK

<u>LOT #</u>	<u>TOTAL LOT AREA PER FINAL PLAT</u>	<u>USEABLE AREA FOR ASSESSMENT PURPOSES</u>
1.	411,877	367,277
2.	1,276,204	1,040,304
3.	380,604	262,304
4.	231,851	108,351
5.	180,700	117,700
6.	170,106	123,106
7.	84,521	84,521
8.	84,628	84,628
9.	85,750	85,750
10.	85,750	85,750
11.	92,349	92,349
12.	94,800	94,800
13.	97,128	97,128
14.	125,952	125,952
15.	122,267	122,267
16.	148,365	148,365
17.	141,750	141,750
18.	119,250	119,250
19.	121,113	121,113
20.	68,474	68,474
21.	186,417	186,417
22.	141,750	141,750
23.	148,366	148,366
24.	122,267	122,267
25.	126,872	126,872
26.	152,215	152,215
27.	251,726	251,726
28.	160,475	138,075
TOTALS	5,413,527	4,758,827

NOTES:

1. Lot 28 shall be subject to assessments for water, paving, and power only.
2. Lot 1 shall be subject to assessments for power only.
3. Useable area excludes sewer and drainage easements, railroad easements, and floodway areas but does not exclude the normal utility easement areas.

12/23/92

EXHIBIT "F"
PAGE F-2