



Handwritten notes and signatures at the top left of the page.

DATE: OCT 21 2015 11:42 P. 20

Received - DIANE L. BATTIATO, Register of Deeds, Douglas County, NE

# LUMBERYARD DISTRICT

LOTS 1 THROUGH 7, INCLUSIVE, LUMBERYARD DISTRICT, BEING A REPLATTING OF LOTS 7 THROUGH 14, BLOCK 21, AND LOTS 1 THROUGH 12, BLOCK 22, ALL IN THE ORIGINAL TOWN OF MILLARD, TOGETHER WITH LOT 1, MILLARD LUMBER ADDITION, AND ALSO TOGETHER WITH PART OF LOT 7, BLOCK 17, IN SCHOMER'S ADDITION TO EAST MILLARD, AND ALSO TOGETHER WITH THAT PART OF THE SOUTHWEST QUARTER (INCLUDING THE ABANDONED UPRR RIGHT OF WAY THEREIN) OF SECTION 1, TOWNSHIP 14 NORTH, RANGE 11 EAST OF THE 6TH P.M., AND ALSO TOGETHER WITH THE ABANDONED UPRR RIGHT IN THAT PART OF THE SOUTHWEST QUARTER OF SECTION 6, TOWNSHIP 14 NORTH, RANGE 12 EAST OF THE 6TH P.M., ALL IN DOUGLAS COUNTY, NEBRASKA.

LOCATED IN: NE 1/4 SE 1/4, SEC. 1-14-11; SE 1/4 SE 1/4, SEC. 1-14-11; SW 1/4 SW 1/4, SEC. 6-14-12

## LEGAL DESCRIPTION

I HEREBY CERTIFY THAT I HAVE MADE A BOUNDARY SURVEY OF THE SUBDIVISION HEREIN AND THAT PERMANENT MONUMENTS HAVE BEEN PLACED AT ALL CORNERS, ANGLE POINTS AND ENDS OF CURVES ON THE BOUNDARY ON THE PLAT AND THAT PERMANENT MONUMENTS WILL BE PLACED AT ALL CORNERS, ANGLE POINTS AND ENDS OF CURVES ON ALL LOTS AND STREETS WITHIN THE SUBDIVISION TO BE KNOWN AS LOTS 1 THROUGH 7, INCLUSIVE, LUMBERYARD DISTRICT, BEING A REPLATTING OF LOTS 7 THROUGH 14, BLOCK 21, AND LOTS 1 THROUGH 12, BLOCK 22, ALL IN THE ORIGINAL TOWN OF MILLARD, TOGETHER WITH LOT 1, MILLARD LUMBER ADDITION, AND ALSO TOGETHER WITH PART OF LOT 7, BLOCK 17, IN SCHOMER'S ADDITION TO EAST MILLARD, AND ALSO TOGETHER WITH THAT PART OF THE SOUTHWEST QUARTER (INCLUDING THE ABANDONED UPRR RIGHT OF WAY THEREIN) OF SECTION 1, TOWNSHIP 14 NORTH, RANGE 11 EAST OF THE 6TH P.M., AND ALSO TOGETHER WITH THE ABANDONED UPRR RIGHT IN THAT PART OF THE SOUTHWEST QUARTER OF SECTION 6, TOWNSHIP 14 NORTH, RANGE 12 EAST OF THE 6TH P.M., ALL IN DOUGLAS COUNTY, NEBRASKA DESCRIBED AS FOLLOWS: COMMENCING AT A BRASS CAP STAMPED "DOUGLAS COUNTY SURVEYOR" AT THE SOUTHWEST CORNER OF THE SOUTHWEST QUARTER OF SAID SECTION 1; THENCE NORTH 00°01'29" EAST (BEARINGS REFERENCED TO THE NEBRASKA STATE PLANE 2600 COORDINATE SYSTEM), FOR 99.05 FEET, ALONG THE EAST LINE OF SAID SOUTHWEST QUARTER OF SECTION 1, TO A STAR DRILL HOLE ON THE SOUTHWEST LINE OF SAID LOT 1, MILLARD LUMBER ADDITION, AND THE TRUE POINT OF BEGINNING; THENCE ALONG SAID SOUTHWEST LINE THE FOLLOWING FIVE (5) COURSES: 1. THENCE NORTH 42°43'20" WEST FOR 14.50 FEET TO A CONCRETE NAIL; 2. THENCE ALONG A CURVE TO THE LEFT (HAVING A RADIUS OF 218.00 FEET AND A LONG CHORD BEARING NORTH 54°17'30" WEST FOR 100.68 FEET) FOR AN ARC LENGTH OF 101.60 FEET TO A STAR DRILL HOLE; 3. THENCE ALONG A CURVE TO THE RIGHT (HAVING A RADIUS OF 282.00 FEET AND A LONG CHORD BEARING NORTH 62°57'18" WEST FOR 45.39 FEET) FOR AN ARC LENGTH OF 45.44 FEET TO A STAR DRILL HOLE; 4. THENCE NORTH 40°48'34" WEST FOR 1812.82 FEET TO A 3/4" OPEN TOP PIPE; 5. THENCE NORTH 04°08'02" EAST FOR 13.71 FEET TO A 3/4" OPEN TOP PIPE AT THE SOUTHEAST RIGHT OF WAY LINE OF MILLARD AVENUE; THENCE NORTH 49°12'44" EAST FOR 79.11 FEET ALONG SAID SOUTHWEST RIGHT OF WAY LINE TO A 5/8" REBAR WITH 1 1/4" YELLOW PLASTIC CAP STAMPED LS 592 AT THE SOUTHWEST RIGHT OF WAY LINE OF THE ABANDONED UNION PACIFIC RAIL ROAD; THENCE NORTH 40°47'16" WEST FOR 40.01 FEET ALONG SAID SOUTHWEST RIGHT OF WAY LINE TO A STAR DRILL HOLE AT THE CENTER LINE OF MILLARD AVENUE; THENCE NORTH 49°11'19" EAST FOR 111.51 FEET ALONG SAID CENTER LINE TO A STAR DRILL HOLE AT THE NORTHEAST RIGHT OF WAY OF THE ABANDONED UNION PACIFIC RAIL ROAD; THENCE SOUTH 40°48'51" EAST FOR 49.02 FEET ALONG SAID NORTHEAST RIGHT OF WAY LINE TO A 5/8" REBAR WITH 1 1/4" YELLOW PLASTIC CAP STAMPED LS 545 AT THE SOUTHWEST RIGHT OF WAY LINE OF MILLARD AVENUE; THENCE NORTH 49°11'19" EAST FOR 100.00 FEET ALONG SAID SOUTHWEST RIGHT OF WAY LINE TO A 5/8" REBAR THE SOUTHWEST RIGHT OF WAY LINE OF SOUTH 134TH STREET; THENCE SOUTH 40°47'37" EAST FOR 1676.84 FEET ALONG SAID SOUTHWEST RIGHT OF WAY LINE TO A MAG NAIL WITH WASHER STAMPED LS 692 AT THE EAST LINE OF THE SOUTHWEST QUARTER OF SAID SECTION 1; THENCE SOUTH 00°01'29" WEST FOR 152.99 FEET ALONG SAID EAST LINE TO A 5/8" REBAR WITH 1 1/4" YELLOW PLASTIC CAP STAMPED LS 545; THENCE SOUTH 40°47'37" EAST FOR 449.08 FEET TO A STAR DRILL HOLE AT THE SOUTH LINE OF THE SOUTHWEST QUARTER OF SAID SECTION 6; THENCE SOUTH 89°29'30" WEST FOR 131.00 FEET ALONG SAID SOUTH LINE TO A STAR DRILL HOLE ON THE SOUTHWEST RIGHT OF WAY LINE OF THE ABANDONED UNION PACIFIC RAIL ROAD; THENCE NORTH 40°42'35" WEST FOR 53.68 FEET ALONG SAID SOUTHWEST RIGHT OF WAY LINE TO A 5/8" REBAR WITH 1 1/4" YELLOW PLASTIC CAP STAMPED LS 692 AT THE NORTH RIGHT OF WAY LINE OF Q STREET; THENCE SOUTH 89°13'03" WEST FOR 27.78 FEET ALONG SAID NORTH RIGHT OF WAY LINE TO A STAR DRILL HOLE AT THE SOUTHWEST CORNER OF SAID LOT 1, MILLARD LUMBER ADDITION; THENCE ALONG THE SOUTHWEST LINE OF SAID LOT 1, MILLARD LUMBER ADDITION THE FOLLOWING FOUR (4) COURSES: 1. THENCE NORTH 40°25'45" WEST FOR 9.76 FEET TO A STAR DRILL HOLE; 2. THENCE NORTH 00°36'27" EAST FOR 7.54 FEET TO A 5/8" REBAR; 3. THENCE SOUTH 89°44'21" WEST FOR 6.50 FEET TO A STAR DRILL HOLE; 4. THENCE NORTH 40°27'56" WEST FOR 58.23 FEET TO THE POINT OF BEGINNING. AND ALSO TOGETHER WITH LOTS 7 THROUGH 14, INCLUSIVE, BLOCK 21, AND LOTS 1 THROUGH 12, INCLUSIVE, BLOCK 22, ALL IN THE ORIGINAL TOWN OF MILLARD, NOW A PART OF THE CITY OF OMAHA, AS SURVEYED, PLATTED AND RECORDED IN DOUGLAS COUNTY, NEBRASKA, CONTAINS: 14-484 JERRE.

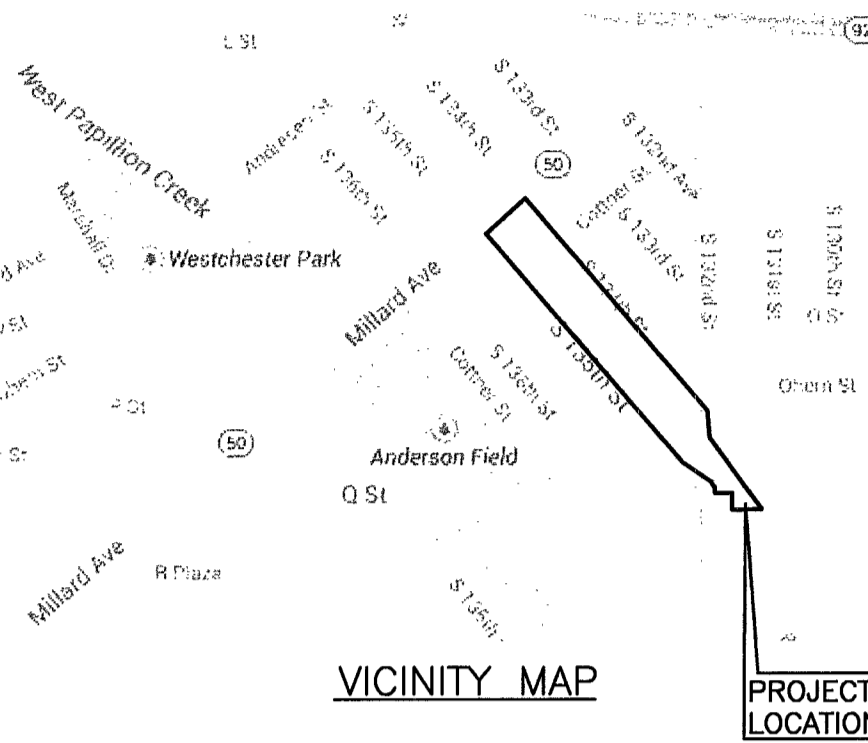

## SECTION CORNER TIES

SE CORNER, SE 1/4 SEC. 1, T14N, R11E FOUND BRASS CAP STAMPED "DOUGLAS COUNTY SURVEYOR" -NE 68.43' TO "X" IN SW CORNER OF METAL TRAFFIC SIGNAL BASE -SE 62.17' TO "X" IN NW CORNER OF METAL TRAFFIC SIGNAL BASE -W 10.58' TO "X" IN E RM OF MANHOLE -NW 55.89' TO "X" IN SE CORNER OF METAL TRAFFIC SIGNAL BASE SW CORNER, SE 1/4 SEC. 1, T14N, R11E SECTION CORNER TIES: FOUND BRASS CAP -NE 64.31' TO THE SW CORNER OF ELECTRICAL BOX LID -NE 39.23' TO "X" IN CONCRETE BASE OF TRAFFIC SIGNAL -SE 32.85' TO "X" IN SW RM OF MANHOLE LID -SW 52.58' TO "X" IN CONCRETE BASE OF TRAFFIC SIGNAL RM SE CORNER OF SW 1/4 SEC. 6, T14N, R12E FOUND BRASS CAP -45.06' NE TO "X" NAILS ON WEST FACE OF POWER POLE -46.29' SW TO CHISELED "X" AT NE SIDE OF CURB INLET MANHOLE RM -85.92' NW TO 600 NAIL ON SE FACE OF POWER POLE NW CORNER, SW 1/4 SEC. 6, T14N, R12E SECTION CORNER TIES: FOUND BRASS CAP STAMPED "DOUGLAS COUNTY SURVEYOR" -NW 30.94' TO "X" NAILS IN SE FACE OF POWER POLE -SE 44.92' TO "X" NAILS IN NW FACE OF POWER POLE -NE 89.12' TO "X" NAILS IN NW FACE OF POWER POLE

## COUNTY TREASURER'S CERTIFICATE

THIS IS TO CERTIFY THAT I FIND NO REGULAR NOR SPECIAL TAXES DUE OR DELINQUENT AGAINST THE PROPERTY DESCRIBED IN THE LAND SURVEYOR'S CERTIFICATE AND EMBRACED IN THIS PLAT, AS SHOWN BY THE RECORDS OF MY OFFICE, THIS 5th DAY OF AUGUST, 2015. DOUGLAS COUNTY TREASURER



## APPROVAL OF CITY ENGINEER OF OMAHA

I HEREBY APPROVE THIS PLAT OF LOTS 1 THROUGH 7, INCLUSIVE, LUMBERYARD DISTRICT AS TO THE DESIGN STANDARDS. Dated 6/16/15 CITY ENGINEER

I HEREBY CERTIFY THAT ADEQUATE PROVISIONS HAVE BEEN MADE FOR THE COMPLIANCE WITH CHAPTER 21-3 OF THE OMAHA MUNICIPAL CODE. Dated 10/21/15 CITY ENGINEER

## APPROVAL OF OMAHA CITY PLANNING BOARD

THIS PLAT OF LOTS 1 THROUGH 7, INCLUSIVE, LUMBERYARD DISTRICT WAS APPROVED BY THE OMAHA CITY PLANNING BOARD THIS 3rd DAY OF April, 2015. CHAIRMAN, OMAHA CITY PLANNING BOARD

## APPROVAL OF OMAHA CITY COUNCIL

THIS PLAT OF LOTS 1 THROUGH 7, INCLUSIVE, LUMBERYARD DISTRICT WAS APPROVED AND ACCEPTED BY THE CITY COUNCIL OF OMAHA, NEBRASKA, THIS 2nd DAY OF July, 2015. Mayor: Sean Stoltz, City Clerk: Ben Bray

## REVIEW BY DOUGLAS COUNTY ENGINEER

THIS PLAT OF LOTS 1 THROUGH 7, INCLUSIVE, LUMBERYARD DISTRICT WAS REVIEWED BY THE DOUGLAS COUNTY ENGINEER ON 3/5/15. DOUGLAS COUNTY ENGINEER

PARCEL AREA TABLE with columns for Parcel # and Area (SF)

LOT CURVE TABLE with columns for Curve #, Radius, Chord Bearing, Chord Length, Arc Length, and Delta

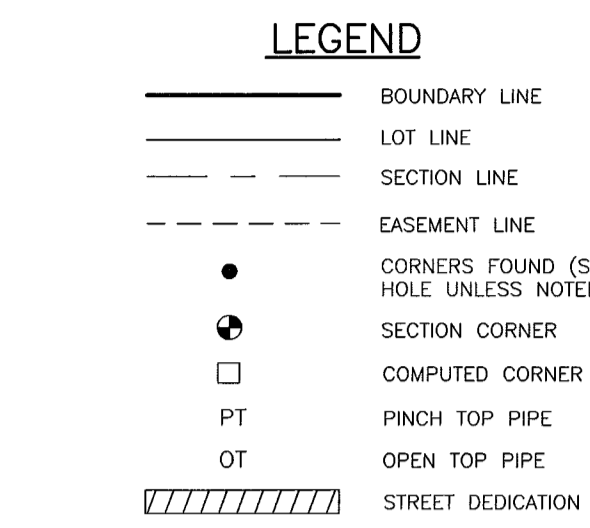

## NOTES

- 1. ALL DISTANCES ARE SHOWN IN DECIMAL FEET.
2. ALL DISTANCES SHOWN ALONG CURVES ARE ARC DISTANCES NOT CHORD DISTANCES.
3. ALL ANGLES ARE 90° UNLESS OTHERWISE NOTED.
4. DISTANCES AND ANGLES SHOWN IN PARENTHESES REFER TO EASEMENTS.
5. ALL EXISTING EASEMENTS ARE NOT BEING REDEDICATED AND ARE SHOWN FOR REFERENCE ONLY.
6. LOT 7 WILL HAVE NO DIRECT VEHICULAR ACCESS TO Q STREET.
7. LOT 1 WILL HAVE NO DIRECT VEHICULAR ACCESS TO MILLARD AVENUE.
8. RIGHT OF WAY DEDICATION AND EASEMENT DETAILS ARE ON SHEET 2 OF 2.
9. A PERPETUAL EASEMENT TO THE OMAHA PUBLIC POWER DISTRICT AND CENTURYLINK AND TO ANY COMPANY WHICH HAS BEEN GRANTED A FRANCHISE UNDER THE AUTHORITY OF THE CITY COUNCIL OF OMAHA, NEBRASKA, TO PROVIDE A CABLE TELEVISION AND ELECTRONIC COMMUNICATION SYSTEM IN THE AREA TO BE SUBDIVIDED WILL BE RECORDED VIA A SEPARATE DOCUMENT.

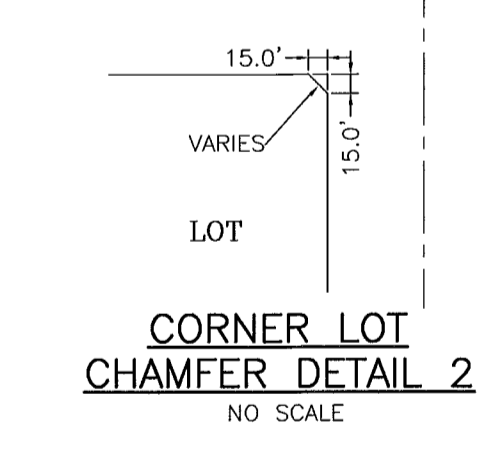
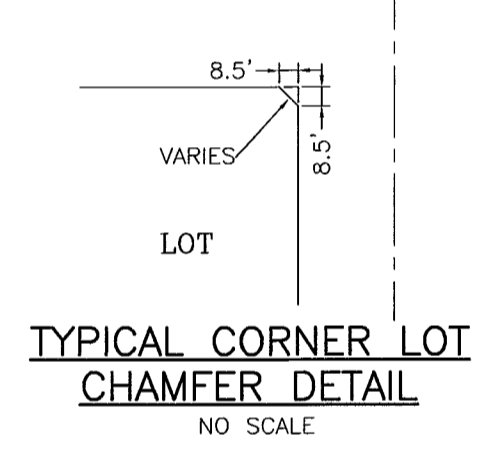

## DEDICATION

KNOW ALL PERSONS BY THESE PRESENTS THAT WE, LANOHA 135 MILLARD LLC, OWNERS OF THE LAND DESCRIBED IN THE LAND SURVEYOR'S CERTIFICATE AND EMBRACED WITHIN THIS PLAT, HAVE CAUSED SAID LAND TO BE SUBDIVIDED INTO LOTS AND STREETS TO BE NUMBERED AND NAMED AS SHOWN HEREON, SAID SUBDIVISION TO BE HEREAFTER KNOWN AS LOTS 1 THROUGH 7, INCLUSIVE, LUMBERYARD DISTRICT; DO HEREBY RATIFY AND APPROVE OF THE DISPOSITION OF OUR PROPERTY AS SHOWN ON THIS PLAT; AND WE DO HEREBY DEDICATE TO THE PUBLIC THE STREETS AS SHOWN HEREON.

JASON P. LANOHA, MANAGER (OWNER PRINTED NAME) and Signature of Jason P. Lanoha

## ACKNOWLEDGEMENT OF NOTARY

STATE OF NEBRASKA )
COUNTY OF DOUGLAS )
THE FOREGOING INSTRUMENT WAS ACKNOWLEDGED BEFORE ME THIS 4th DAY OF March, 2015

BY Jason P. Lanoha, Manager (OWNER PRINTED NAME) and Signature of Jason P. Lanoha
ON BEHALF OF LANOHA 135 MILLARD LLC, A NEBRASKA LIMITED LIABILITY COMPANY.
SIGNATURE OF NOTARY PUBLIC

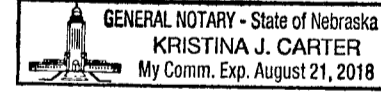

Administrative information including 'drawn by EAM', 'designed by', 'reviewed by MRT', 'file name', 'revisions', 'job number-taaka 0114040.01-003', 'book page 2-24-2015', 'sheet 1 of 2', and 'FINAL PLAT'.

Vertical text on the far left edge of the page.

# LUMBERYARD DISTRICT

LOTS 1 THROUGH 7, INCLUSIVE, LUMBERYARD DISTRICT, BEING A REPLATING OF LOTS 7 THROUGH 14, BLOCK 21, AND LOTS 1 THROUGH 12 BLOCK 22, ALL IN THE ORIGINAL TOWN OF MILLARD, TOGETHER WITH LOT 1, MILLARD LUMBER ADDITION, AND ALSO TOGETHER WITH PART OF LOT 7, BLOCK 17, IN SCHOMER'S ADDITION TO EAST MILLARD, AND ALSO TOGETHER WITH THAT PART OF THE SOUTHEAST QUARTER (INCLUDING THE ABANDONED UPRR RIGHT OF WAY THEREIN) OF SECTION 1, TOWNSHIP 14 NORTH, RANGE 11 EAST OF THE 6TH P.M., AND ALSO TOGETHER WITH THE ABANDONED UPRR RIGHT IN THAT PART OF THE SOUTHWEST QUARTER OF SECTION 5, TOWNSHIP 14 NORTH, RANGE 12 EAST OF THE 6TH P.M., ALL IN DOUGLAS COUNTY, NEBRASKA.

LOCATED IN:  
NE 1/4 SE 1/4, SEC. 1-14-11  
SE 1/4 SE 1/4, SEC. 1-14-11  
SW 1/4 SW 1/4, SEC. 6-14-12

drawn by	EAM
designed by	
reviewed by	MRT
revisions	

14040102.dwg

NO.	DATE	DESCRIPTION

14710 West Dodge Road, Suite 100  
Omaha, Nebraska 68154-2027  
www.LRA-inc.com

LAMP RYNEARSON & ASSOCIATES  
LUMBERYARD DISTRICT (LOTS 1-7, INCLUSIVE)  
OMAHA, DOUGLAS COUNTY, NEBRASKA

FINAL PLAT

job number-tasks  
0114040.01-003

book page  
2-24-2015

date  
sheet  
2 of 2

**LEGEND**

- BOUNDARY LINE
- LOT LINE
- SECTION LINE
- EASEMENT LINE
- CORNERS FOUND (STAR DRILL HOLE UNLESS NOTED OTHERWISE)
- SECTION CORNER
- PT PINCH TOP PIPE
- OT OPEN TOP PIPE
- STREET DEDICATION

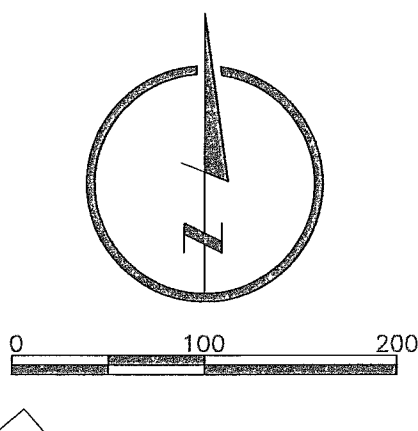

- NOTES**
1. ALL DISTANCES ARE SHOWN IN DECIMAL FEET.
  2. ALL DISTANCES SHOWN ALONG CURVES ARE ARC DISTANCES NOT CHORD DISTANCES.
  3. ALL ANGLES ARE 90° UNLESS OTHERWISE NOTED.
  4. DISTANCES AND ANGLES SHOWN IN PARENTHESES REFER TO EASEMENTS.
  5. ALL EXISTING EASEMENTS ARE NOT BEING REDDEDICATED AND ARE SHOWN FOR REFERENCE ONLY.
  6. LOT 7 WILL HAVE NO DIRECT VEHICULAR ACCESS TO Q STREET.
  7. LOT 1 WILL HAVE NO DIRECT VEHICULAR ACCESS TO MILLARD AVENUE.
  8. RIGHT OF WAY DEDICATION AND EASEMENT DETAILS ARE ON SHEET 2 OF 2.
  9. A PERPETUAL EASEMENT TO THE OMAHA PUBLIC POWER DISTRICT AND CENTURYLINK AND TO ANY COMPANY WHICH HAS BEEN GRANTED A FRANCHISE UNDER THE AUTHORITY OF THE CITY COUNCIL OF OMAHA, NEBRASKA, TO PROVIDE A CABLE TELEVISION AND ELECTRONIC COMMUNICATION SYSTEM IN THE AREA TO BE SUBDIVIDED WILL BE RECORDED VIA A SEPARATE DOCUMENT.

**REVIEW BY DOUGLAS COUNTY ENGINEER**

THIS PLAT OF LOTS 1 THROUGH 7, INCLUSIVE, LUMBERYARD DISTRICT WAS REVIEWED BY THE DOUGLAS COUNTY ENGINEER'S OFFICE

DATE: 3/5/15

DOUGLAS COUNTY ENGINEER

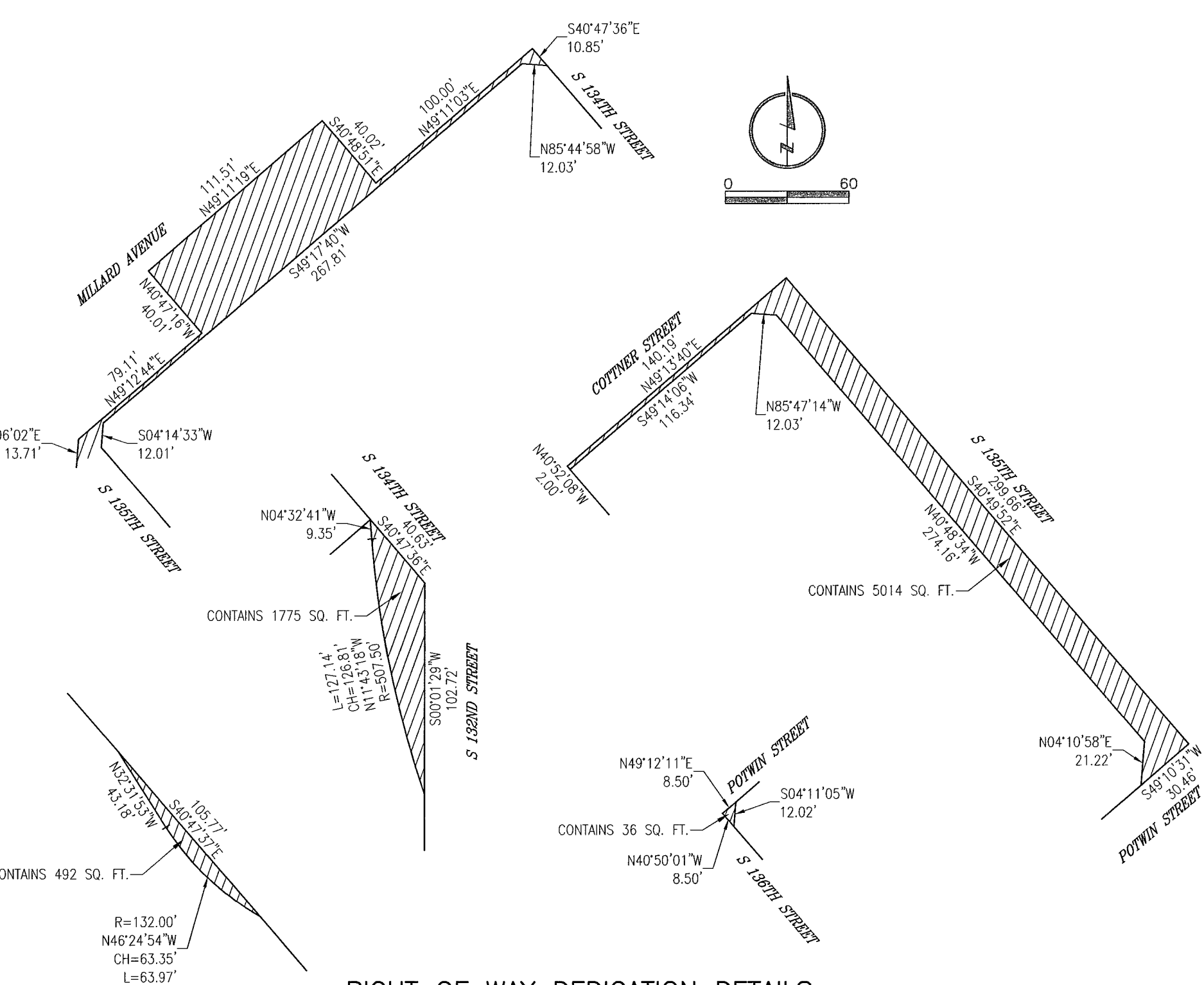
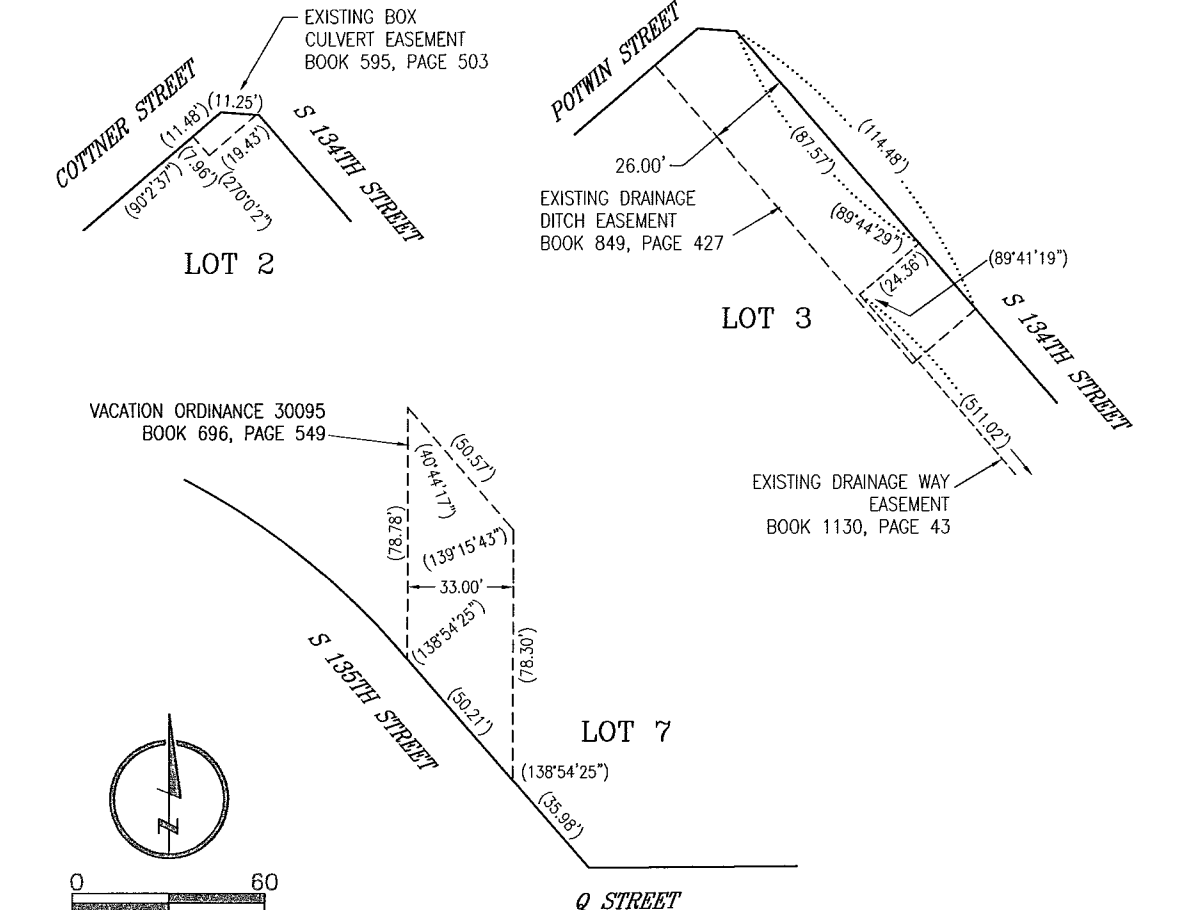
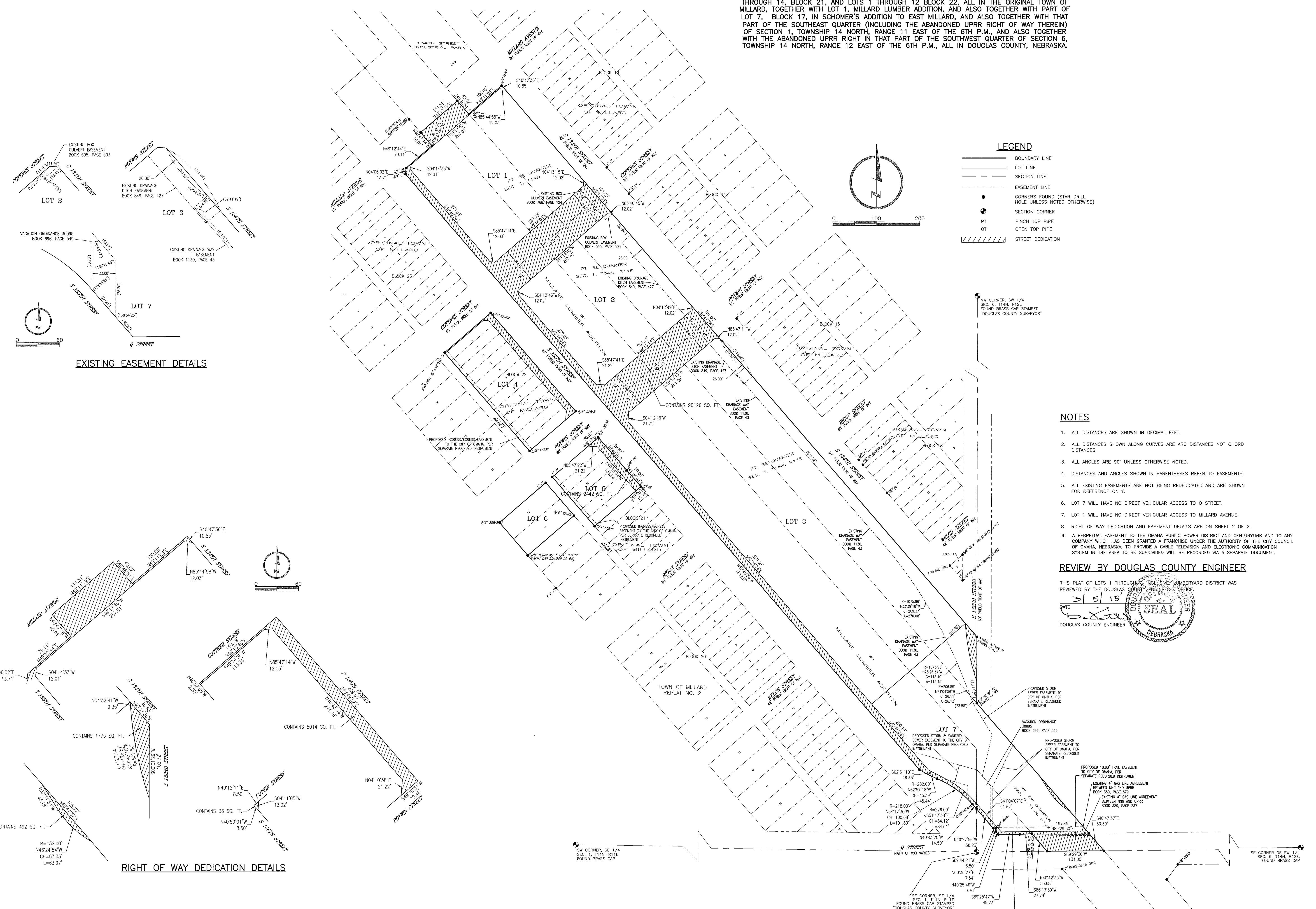

RIGHT OF WAY DEDICATION & EXISTING EASEMENT DETAILS